



White Paper

Blu-ray Disc™ Format

1. B Physical Format Specifications for BD-R

5th Edition

October, 2010

White Paper Blu-ray Disc™ Format BD-R

Condition of Publication

COPYRIGHT

All rights reserved. This document contains information that is proprietary information of the Blu-ray Disc Association and its members and may not be used, copied or distributed without the written permission of the Blu-ray Disc Association or its License Office. All other use, copying and distribution are prohibited.

TRADEMARK

Blu-ray Disc™, Blu-ray™, Blu-ray 3D™, BD-Live™, BONUSVIEW™, BDXL™, AVCREC™, and the logos are trademarks of the Blu-ray Disc Association.

DISCLAIMER

The information contained herein is believed to be accurate as of the date of publication. However, none of the Blu-ray Disc Association, its Members, or its License Office will be liable for any damages, including indirect or consequential, from use of the White Paper or reliance on the accuracy of this document.

LICENSING

License is required from the Blu-ray Disc Association for the application of the System Description Blu-ray Disc™ Format in both disc and equipment products.

NOTICE

For any further explanation of the contents of this document, or in case of any perceived inconsistency or ambiguity of interpretation, please consult with:

Blu-ray Disc Association

License Office
10 Universal City Plaza, T-100,
Universal City, CA 91608 U.S.A.

Fax.: +1-818-763-9027
Web Site: <http://www.blu-raydisc.info>
E-mail: agent@bul-raydisc.info

INDEX

1. Main Parameters of Recordable Blu-ray Disc™
2. Recording and Playback Technology
 - 2.1 Track Format
 - 2.2 Recording and playback Principles
 - 2.3 Write Strategy
 - 2.3.1 N-1 Write Strategy
 - 2.3.2 N/2 Write Strategy
 - 2.3.3 Castle Write Strategy
 - 2.4 Tilt Margin
 - 2.5 Limit-Equalizer
 - 2.6 Measurement Results
3. BDXL™ Technologies
 - 3.1 Main Parameters
 - 3.2 Disc Structure
 - 3.3 Extended Adaptive Write Strategy
 - 3.4 i-MLSE Technology
4. Modulation Code and Error Correction Code
 - 4.1 Modulation Code
 - 4.2 Error Correction Code
5. Address Format Using Groove Wobbles
6. Disc Management
 - 6.1 Defect Management and Logical Overwrite
 - 6.2 Recording Management

**White Paper Blu-ray Disc™ Format
BD-R**

1. Main Parameter of Recordable Blu-ray Disc™

1. Main Parameter of Recordable Blu-ray Disc™

Table 1.1 shows the main parameters of Blu-ray Disc™ Recordable (BD-R). To maximize capacity and performance, the main optical system parameters of the Blu-ray™ Recordable Disc include a laser diode with a wavelength 405 nm and an objective lens with a NA of 0.85. Additionally, the current maximum user data transfer rate is 216 Mbps (6x) for SL (Single Layer) & DL (Dual Layer), and 144 Mbps (4x) for TL (Triple Layer) & QL (Quadruple Layer) which will be explained in Chapter 4. The channel modulation is 17PP ((1, 7) RLL Parity-Preserve, Prohibit Repeated Minimum Transition Runlength code) and the recording area can be either on-Groove or in-Groove.

Table 1.1: Main parameters for SL & DL

	Recordable Blu-ray Disc™	
Diameter	120 mm	80 mm
Capacity	(SL) 25 GB, 27 GB (DL) 50 GB, 54 GB	(SL) 7.8 GB (DL) 15.6 GB
Wavelength of laser diode	405nm	
Recording Power	(SL) : ≤ 6 mW (1x), ≤ 7 mW (2x), ≤ 10.5 mW (4x), ≤ 14 mW (6x) (DL) : ≤ 12 mW (1x), ≤ 14 mW (2x), < 18 mW (4x), < 22 mW (6x)	
NA of objective lens	0.85	
Cover Layer thickness	0.10 mm (L0,SL), 0.075 mm (L1)	
Recording Area	On Groove / In Groove	
Address method	MSK (Minimum Sequence Keying) & STW (Saw Tooth Wobble)	
Rotation	CLV (Constant Linear Velocity)	
Track Pitch	0.32 μm	
Channel modulation	17PP	
Minimum Mark length	0.149 μm for 25 GB, 50 GB	0.149 μm
Total efficiency	81.70 %	
User Data transfer rate	36 Mbps ~ 216 Mbps	

Figure 1.1 specifies the outline of the Groove geometries for On-Groove and In-Groove. The Groove is defined as the portion of the disc that is recorded by the Laser Beam Recorder.

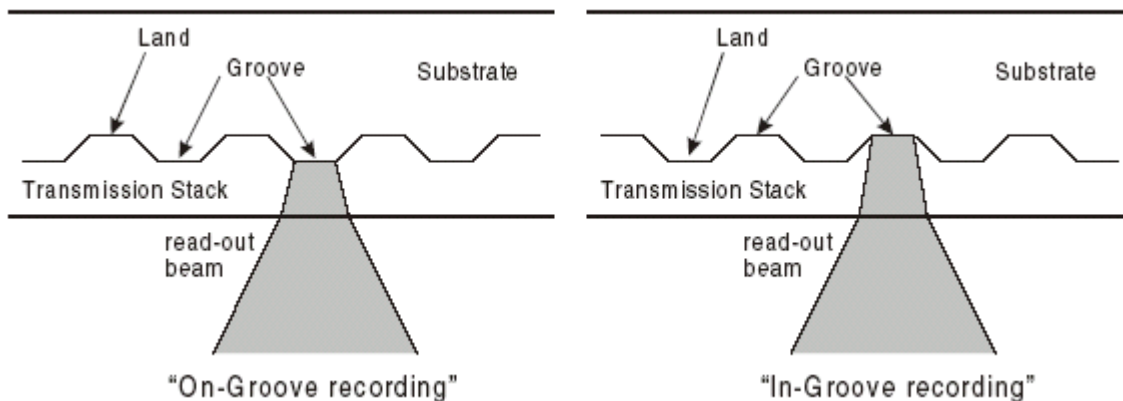

Fig.1.1 Outline of Groove geometry

2. Recording and Playback Technologies

2.1 Track Format

The Track format of Recordable Blu-ray Disc™ is Groove-recording, i.e., recording data only On-Groove or In-Groove Tracks. For the Groove recording method, Lands are sandwiched between adjacent Grooves to block heat transfer between the Grooves during recording, preventing signal quality deterioration in one Groove Track due to the influence of recording data in an adjacent Groove Tracks with a narrow Track Pitch. The Track Pitch between Grooves in Recordable Blu-ray Disc™ is 0.32 μm .

2.2 Recording and Playback Principles

The Recordable Layer(s) for a Recordable Blu-ray Disc™ employ either organic or inorganic materials. For a Single Layer Recordable Blu-ray Disc™, the thickness from the disc surface to the Recording Layer is 100 μm . For a Dual Layer Recordable Blu-ray Disc™, the thickness from the disc surface to the Front Layer (Layer 1) is 75 μm , and to the Rear Layer (Layer 0) is 100 μm . For the Dual Layer disc, the laser beam must be transmitted through the Front Layer for data recording/playback on the Rear Layer. While Recording Layer 0, the laser beam is severely out of focus for Layer 1 resulting in a very low optical density which prevents affecting the recording characteristics of Layer 1. Therefore, the Front Layer is required to provide an optical transmittance of 50% or more, regardless of its recorded state (whether data-recorded or blank).

The Recordable Blu-ray Disc™ specification allows for multiple variations in the recording capacity, to allow user's selection according to the disc purchased. According to the Specifications Book, the 120 mm Single Layer type has two different discs with capacities of 25 and 27 GB, while the Dual Layer type has capacities of 50 and 54 GB. The two different capacities of each type have been realized by using different linear recording densities, but all using the same Track Pitch. The minimum length (2T) of Marks recordable on a disc is 0.149 and 0.138 μm , in the order of the recording capacity. Additionally, the Recordable Blu-ray Disc™ specification allows for 80 mm discs using a single linear recording density. This results in capacities of 7.8 GB for Single Layer and 15.6 GB for Dual Layer 80 mm discs.

The basic recording/playback system for the Recordable Blu-ray Disc™ is shown in Fig. 2.2.1. The User Data, already properly formatted (ECC (Error Correction Code) and other Sector Information added), is modulated or encoded into a 17PP (one seven Parity Preserving) NRZI (Non-Return to Zero Invert) signal. This 17PP NRZI is sent to a write pulse compensator where the signal is modulated into a multi-pulse signal (see Fig. 2.3.1.1). By adjusting the leading edge of the first pulse and the trailing edge of the cooling pulse of the multi-pulse signal, we can control the amount of thermal accumulation relative to the Mark length, enabling the accurate placement of Mark edges. The pulse waveform thus modulated is sent to a laser driver circuit, which modulates the power of laser beam to record Mark/Space data on a Recordable Blu-ray Disc™. To play-back recorded data, the reproduced signal is fed through an Equalizer to the Phase Lock Loop (PLL). The output signal of the Equalizer is also fed to the Analog to Digital converter (A/D) to be converted to a digital signal using the PLL clock timing. The output of the A/D is then passed through a PRML (Partial Response Maximum Likelihood) channel to correct any initial bit errors, and output as a NRZI signal to demodulated from the 17PP code and any remaining errors corrected using the ECC (for more information see section 3).

White Paper Blu-ray Disc™ Format BD-R

2. Recording and Playback Technologies

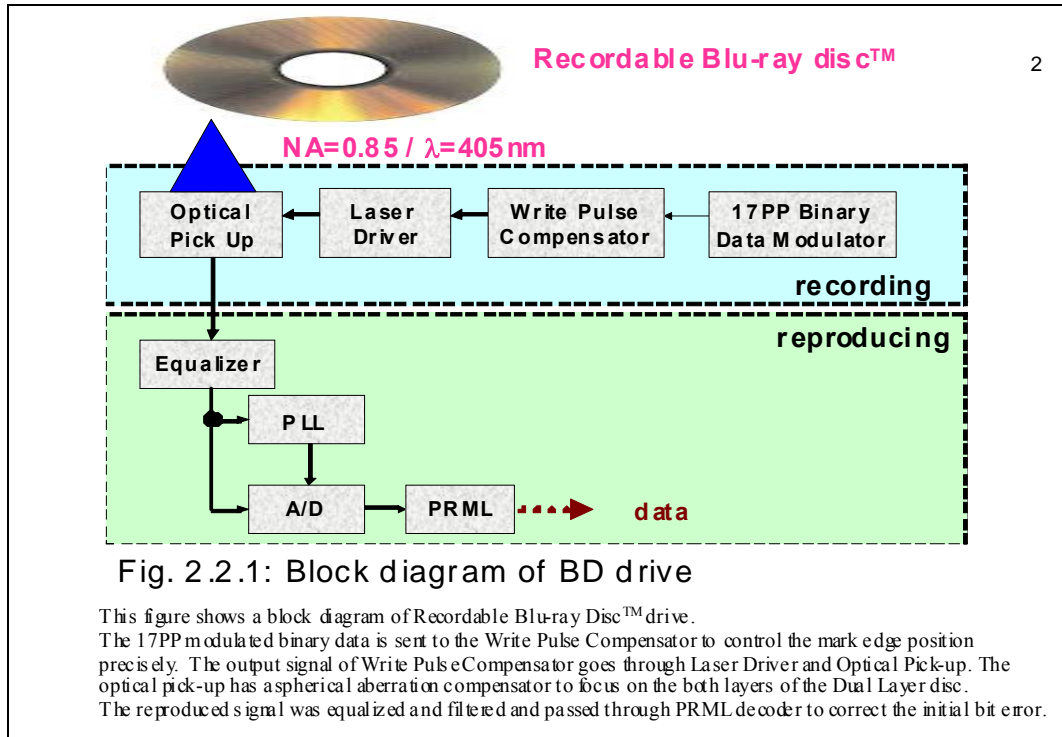

Fig. 2.2.1 Basic recording/playback system of BD-R

As previously stated, the Recording Layer where the actual Marks and Spaces are formed employs either organic or inorganic materials. Fig. 2.2.2 shows the typical disc structures of Recordable Blu-ray discs™. For example, Fuji Photo Film Co., Ltd. has successfully demonstrated BD-R that can be readily put into commercial production using organic materials. Furthermore, TDK has realized BD-R discs using inorganic materials (a Cu alloy layer and a Si layer). In addition to the type of inorganic materials used by TDK, it is also possible to use write-once phase change materials.

The mechanism of forming Marks on TDK's media is described as follows. As the Recordable Blu-ray Disc™ is irradiated with a train of modulated optical pulses of 2T, 3T and 4T as shown in Fig. 2.2.3, the recording Marks corresponding to their respective code lengths are formed on the disc. A part of the film (recorded Marks) where the laser beam is irradiated with higher power pulses will be heated and the two different films of Cu alloy and Si are mixed forming a CuSi -Alloy with lower reflectivity (Fig 2.2.4). The spaces between the Marks remain in their original state since the irradiation between the Marks is at a lower power.

This general method of using higher power irradiation to form Marks and lower power for Spaces is consistent across both organic and inorganic materials; however the write pulse waveform will differ in each case. For the recorded optical disc of either organic or inorganic material, the Optical Pickup using a focused laser beam reads differences in the physical characteristics (reflectivity) between the thus formed marks and spaces, thereby producing binary data in accordance with the reflectivity level.

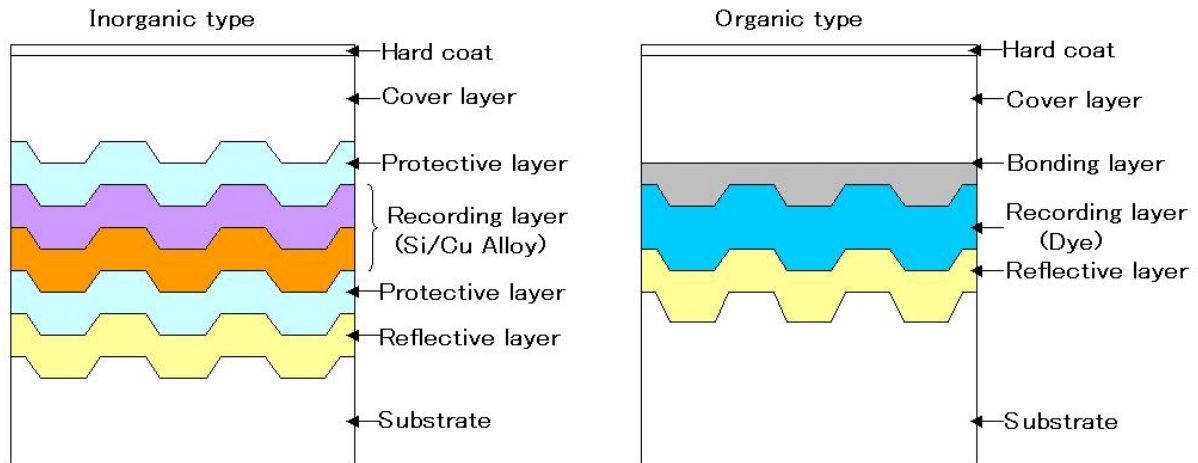

Fig. 2.2.2 Disc structure

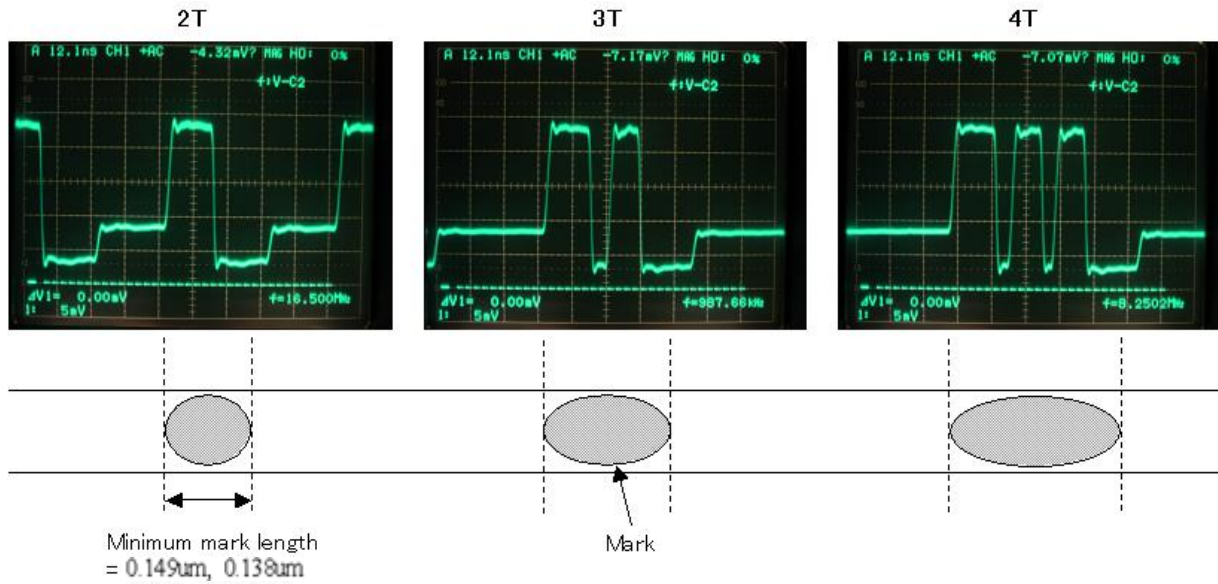

Fig. 2.2.4 TEM image of Recorded Mark on TDK's BD-R disc

2. Recording and Playback Technologies

Regarding the organic materials, the recording and playback mechanism is similar to Dye-based DVD-R media. As is shown in Fig. 2.2.5, excellent recording Pit formation was obtained even at recording densities approximately five times greater than those of DVD-R media (equivalent to 25GB capacity on a 12cm-diameter disc). Some measurement results of recording/playback signal quality will be shown in section 2.6.

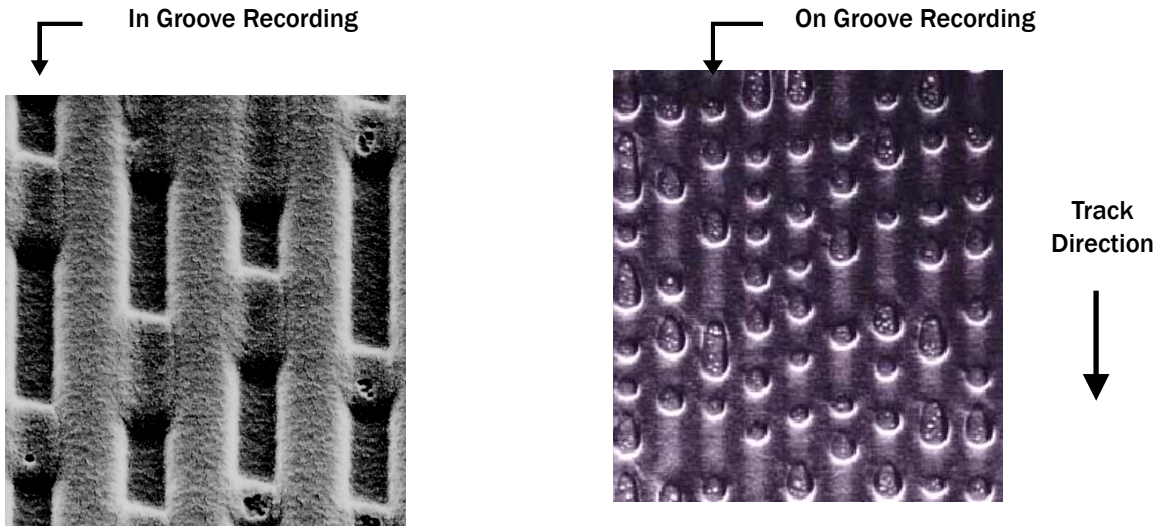

Fig. 2.2.5 SEM Photos of Recording Pits on Organic Dye-Based Optical Discs

2.3 Write Strategy

Three types of Write Strategies are defined in the Blu-ray Disc™ Recordable format; N-1 Write Strategy which requires one additional write pulse for each channel clock cycle beginning with a single pulse for a 2T Mark is applied for discs.

N/2 Write Strategy which requires one additional write pulse for each 2 consecutive channel clock cycles is applied for discs. N/2 write strategy has a single write pulse for a 2T or 3T Mark, 2 write pulses for a 4T and 5T Mark, and so on.

Castle Write Strategy which requires continued pulse with several power levels for each Mark is applied for discs.

In accordance with the characteristics of each Recording Layer of a disc, a disc manufacturer determines the Write Strategy parameters and embeds them in the HF modulated Groove Area and the Wobbled Groove address of the disc.

2.3.1 N-1 Write Strategy

Fig. 2.3.1.1 schematically shows the N-1 Write Strategy for Blu-ray Disc™ Recordable format, which comprises pulse-modulated recording waveforms with four power levels of P_W , P_{BW} , P_C and P_S . T_{top} denotes the duration of the first write pulses, dT_{top} the start time offset of the first write pulse from its reference position, T_{MP} the duration of all following write pulses except the last pulse, T_{LP} the duration of the last pulse and dT_S the start time offset of the Space level from its reference position. Fig.2.3.1.1 shows an example of the write pulse waveform of a 4T Mark. The write pulse offsets (dT_{top} and dT_S), the write pulse duration (T_{top} , T_{MP} and T_{LP}) and the power levels (P_W , P_{BW} , P_C and P_S) are shown. To control Mark edge positions precisely, each parameter (dT_{top} , T_{top} , T_{MP} , T_{LP} or dT_S) is defined in 1/16 of the channel clock resolution.

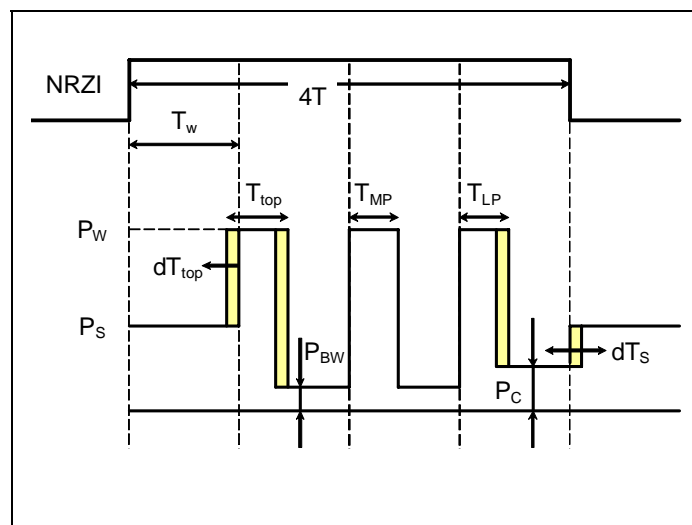

Fig. 2.3.1.1 N-1 Write Strategy

2.3.2 N/2 Write Strategy

Fig. 2.3.2.1 schematically shows N/2 Write Strategy which comprises pulse-modulated recording waveforms with four power levels of P_W , P_{BW} , P_C and P_S . T_{top} denotes the duration of the first pulse, dT_{top} the start time offset of the first pulse from its reference position, T_{MP} the duration of all following write pulses except the last pulse, T_{LP} the duration of the last pulse, and dT_S the start time offset of Space level from its reference position. Fig.2.3.2.1 shows an example of the write pulse waveform of 6T Mark. N/2 Write Strategy has one-half write pulse of Mark length. The write pulse offsets (dT_{top} and dT_S), the write pulse duration (T_{top} , T_{MP} and T_{LP}) and the power levels (P_W , P_{BW} , P_C and P_S) are shown. To control Mark edge positions precisely, each parameter (dT_{top} , T_{top} , T_{MP} , T_{LP} or dT_S) is defined in 1/16 of the system clock resolution.

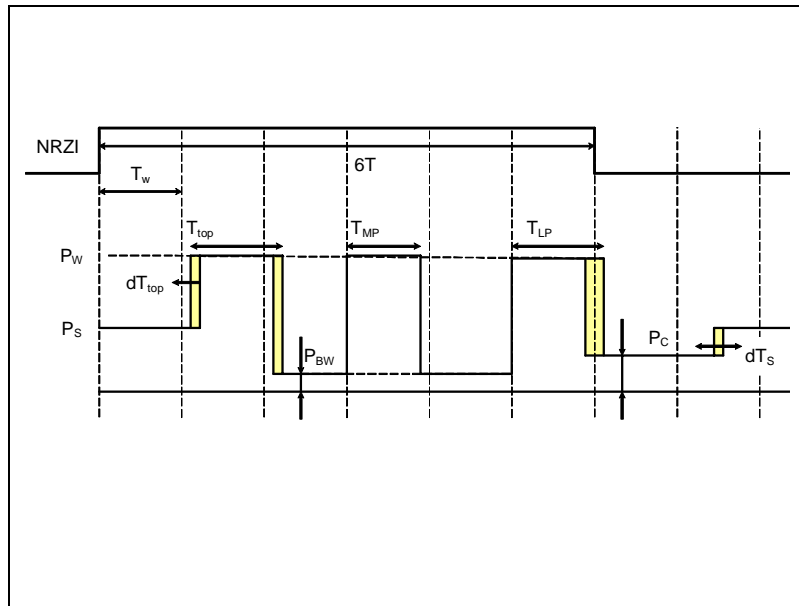

Fig. 2.3.2.1 N/2 Write Strategy

2.3.3 Castle Write Strategy

Fig. 2.3.3.1 schematically shows the Castle Write Strategy which comprises pulse-modulated recording waveforms with four power levels of P_w , P_m , P_c and P_s . T_{top} denotes the duration of the first pulse, dT_{top} the start time offset of the first pulse from its reference position, dT_c the start time offset of the cooling pulse except the 2T write pulse, T_{lp} the duration of the last pulse, and dT_s the start time offset of the Space level from its reference position. Fig.2.3.3.1 shows an example of the write pulse waveform of 6T Mark. The write pulse offsets (dT_{top} , dT_c and dT_s), the write pulse duration (T_{top} and T_{lp}), and the power levels (P_w , P_m , P_c and P_s) are shown. To control Mark edge positions precisely, each parameter (dT_{top} , T_{top} , dT_c , T_{lp} or dT_s) is defined by 1/16 of the channel clock resolution.

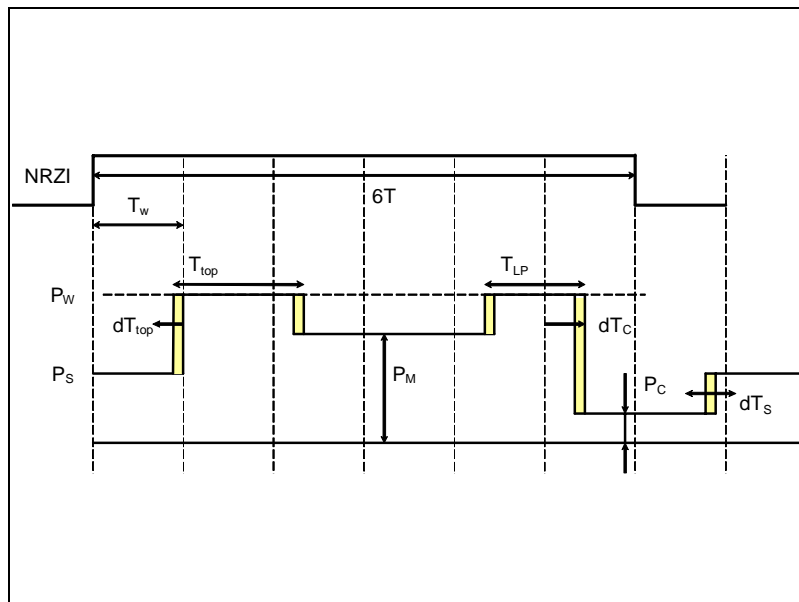

Fig. 2.3.3.1 Castle Write Strategy

2.4 Tilt Margin

Fig. 2.4.1 shows the tangential and radial tilt margin characteristics of a Dual Layer Recordable Blu-ray Disc™ on which data is recorded using adaptive Mark compensation and read out using PRML technology. The recording capacity is 50 GB. Both layers provide satisfactory bit error rate (bER) and tangential and radial tilt margins. The tilt margin of the Front Layer (Layer 1) is wider than that of Rear Layer (Layer 0), due to the thinner Front Layer Substrate and therefore less influence of tilt.

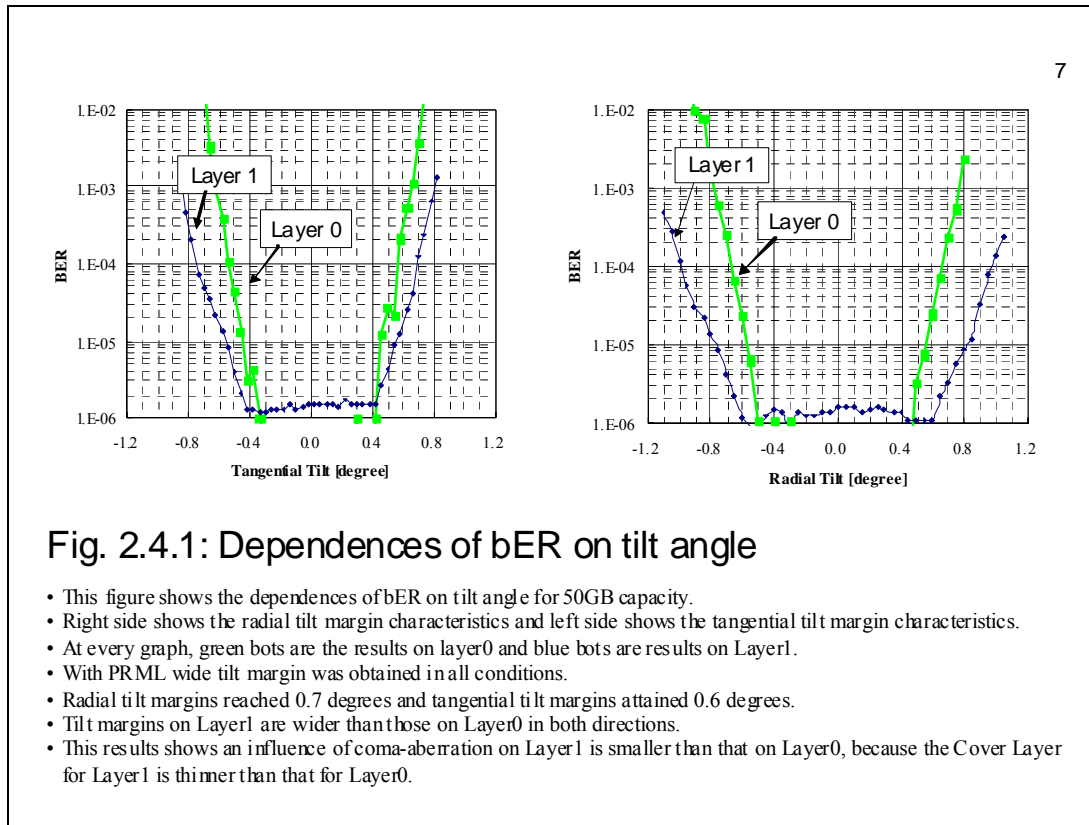

Fig. 2.4.1: Dependences of bER on tilt angle

- This figure shows the dependences of bER on tilt angle for 50GB capacity.
- Right side shows the radial tilt margin characteristics and left side shows the tangential tilt margin characteristics.
- At every graph, green dots are the results on layer0 and blue dots are results on Layer1.
- With PRML wide tilt margin was obtained in all conditions.
- Radial tilt margins reached 0.7 degrees and tangential tilt margins attained 0.6 degrees.
- Tilt margins on Layer1 are wider than those on Layer0 in both directions.
- This results shows an influence of coma-aberration on Layer1 is smaller than that on Layer0, because the Cover Layer for Layer1 is thinner than that for Layer0.

Fig. 2.4.1 Tilt margins

2.5 Limit- Equalizer

Generally, the system for reading a playback signal uses a Linear Equalizer to improve the Signal to Noise ratio (SNR) around minimum-length Marks and to suppress Inter-Symbol Interference. Disc noise exists mainly in a low-frequency region as shown in Fig. 2.5.1. When high frequencies around minimum-length Marks are selectively boosted using a Linear Equalizer, the minimum-Mark-length signal level can be markedly enhanced with only a little increase in the total amount of noise. That is, it is possible to improve the SNR by using a Linear Equalizer that boosts high frequency. However, since an excessive boosting of high frequencies causes an increase in Inter-Symbol Interference, a Conventional Linear Equalizer has a limitation to the improvement of the SNR.

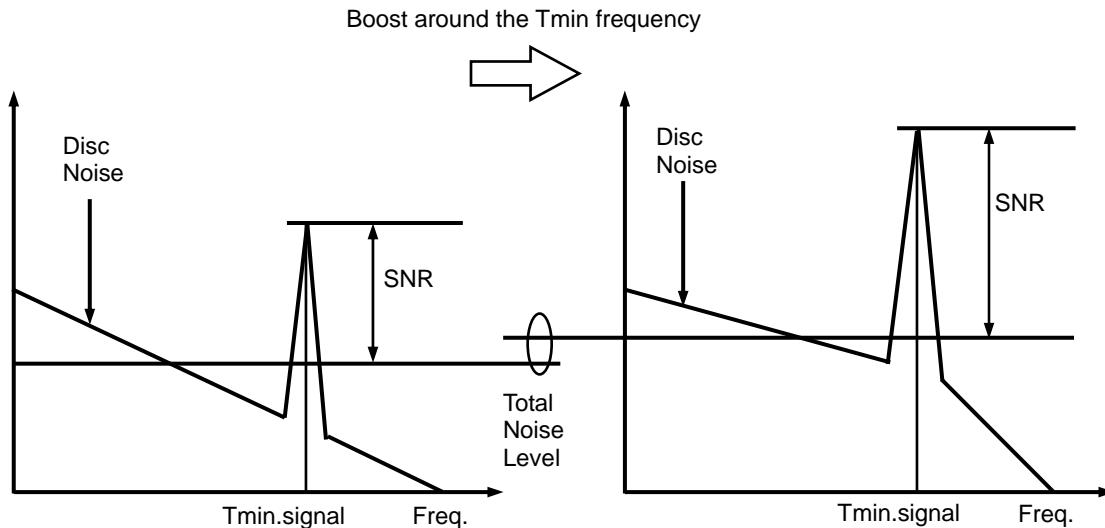

Fig. 2.5.1 SNR improvement by the high frequency boost

A Limit-Equalizer is capable of boosting high frequencies without increasing Inter-Symbol Interference. Fig. 2.5.2 shows the configuration of the Limit-Equalizer system for use in 17PP modulation. In this system, a Pre-Equalizer initially minimizes the Inter-Symbol Interference through the use of a Conventional Linear Equalizer as the Pre-Equalizer. The Limit-Equalizer is located after the Pre-Equalizer.

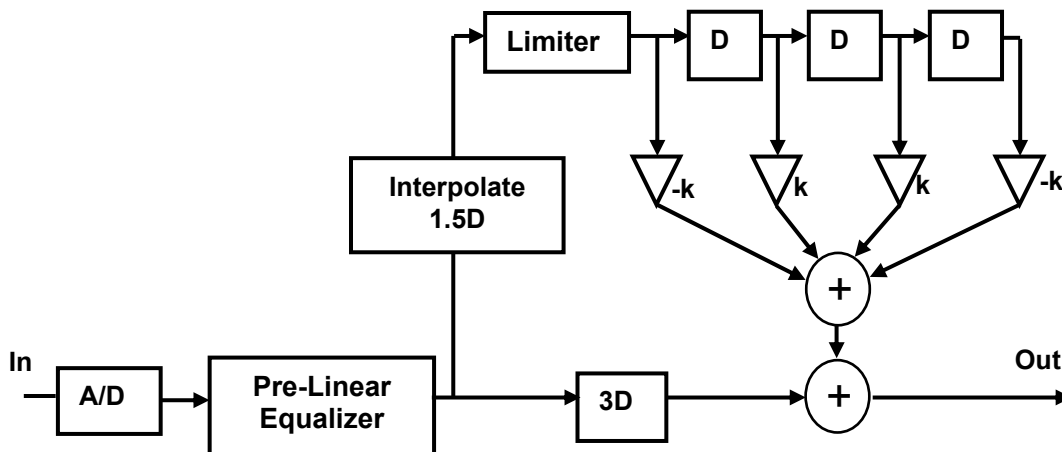

Fig. 2.5.2 Configuration of the Limit-Equalizer

The Limit-Equalizer has a similar construction as a Finite-Impulse-Response (FIR) Linear Equalizer, except that the Limiter restricts the amplitude of part of playback signal. The FIR filter acts as a high-frequency-boosting Equalizer, and its gain is determined by coefficient “k.” The gain of a FIR filter increases with the value of k. Sample values of playback signals are indicated at the small-circle points in Fig. 2.5.3.

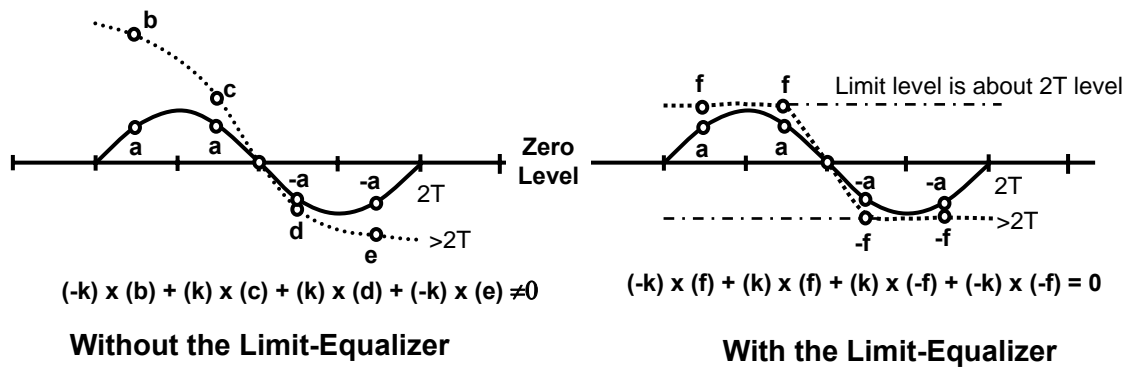

Fig.2.5.3 Behavior of Linear Equalizer and Limit-Equalizer

To understand the operation of the Limit-Equalizer, close attention is paid to the zero-crossing point and the sample values at points close to the zero-cross point. The operation of the Equalizer without a Limiter is as follows. Referring to the left-side chart of Fig. 2.5.3, if playback signal waveform is symmetrical as indicated by the solid line, the data summed up by the Equalizer becomes 0 as expressed by Equation (1), and the zero-crossing point does not move.

$$(-k)x(-a) + (k)x(-a) + (k)x(a) + (-k)x(a) = 0 \quad (1)$$

However, if playback signal waveform is asymmetrical as shown in dotted line, the data summed up by the Equalizer does not become 0 as indicated by Equation (2), resulting in Inter-Symbol Interference.

$$(-k)x(b) + (k)x(c) + (k)x(d) + (-k)x(e) \neq 0 \quad (2)$$

However, if a Limiter is used to restrict the signal amplitude to around the peak amplitude level of the shortest wavelength signal, the waveform becomes symmetrical as shown by dotted line in the right-side chart of Fig. 2.5.3. In that case, the data summed up by the Equalizer is constantly 0, as expressed by Equation (3).

$$(-k)x(-f) + (k)x(-f) + (k)x(f) + (-k)x(f) = 0 \quad (3)$$

The Limiter does not act on a signal with a minimum-length Mark, and the Equalizer amplifies the signal amplitude. For a low-frequency signal with high amplitude, the Limiter restricts the amplitude around the center tap, which is to be added to the sum and the filter gain is effectively decreased. Thus, the Limit-Equalizer can boost high frequencies without increasing the Inter-Symbol Interference, and we can improve the SNR. Fig. 2.5.4 shows the waveform processed by the Limit-Equalizer, in comparison with that processed by the Conventional Linear Equalizer.

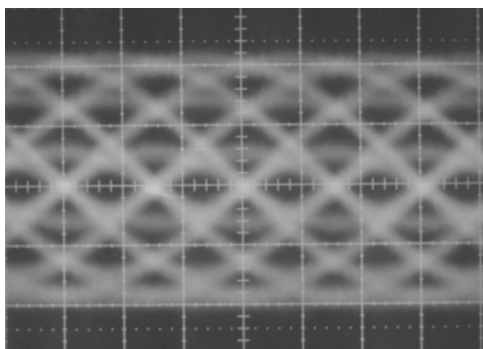

With a Conventional Linear Equalizer

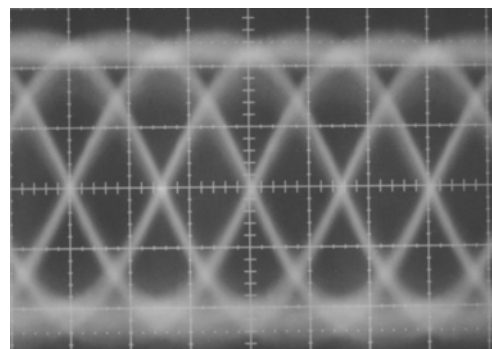

With the Limit-Equalizer

Fig. 2.5.4 Eye diagrams after the Linear Equalizer and the Limit-Equalizer

Since the Blu-ray Disc™ standard adopts high-density recording and 17PP modulation, the minimum Mark length is shorter than for a conventional optical disc, leading to a low SNR. Viterbi decoding in the disc drive can compensate for the low SNR, to achieve good playback performance. However, since Viterbi-decoding output is the result after 1/0 determination and is poor in sensitivity, it is not suitable for use in evaluating optical discs in general. The jitter of signals processed by a Linear Equalizer is dominated by the component attributed to the noise of disc itself rather than the component attributed to the quality of recording Marks, making it difficult to determine whether or not the recording state is optimal. In this regard, a Linear Equalizer is not suitable for use in disc evaluation. The Blu-ray Disc™ system employs a Limit-Equalizer to improve the SNR and to measure jitter for disc evaluation. With the Limit-Equalizer, it is possible to determine the quality of recorded Marks with high sensitivity.

2.6 Measurement Results

This section outlines some measurement results using the technologies explained in section 2. Fig. 2.6.1 shows a satisfactory signal quality even when recording at a data transfer speed of 72Mbps (equivalent to 2x BD-R recording) using an organic Dye material for BD-R disc.

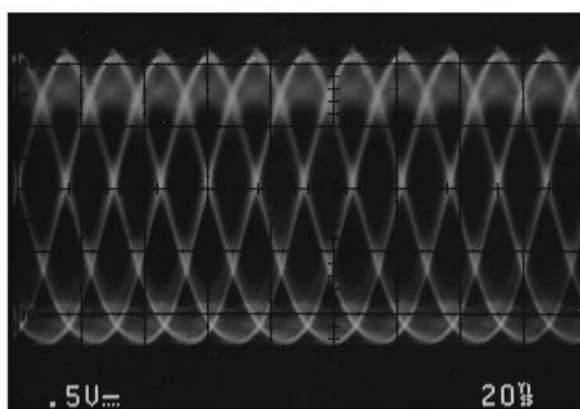
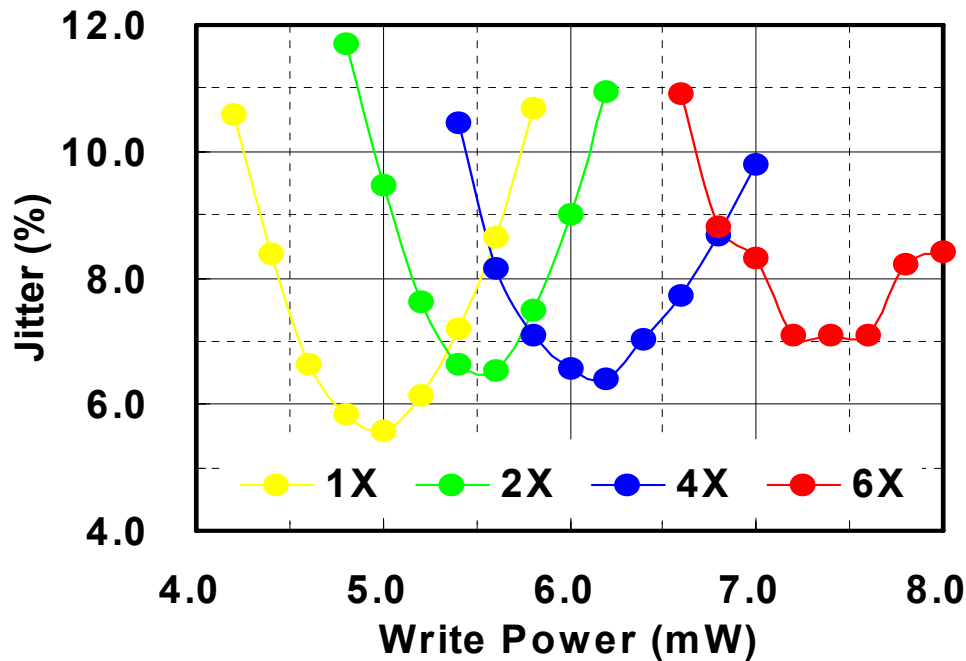

Fig. 2.6.1 Eye Pattern of Reproducing Signal of Dye-Based BD-R after 2x recording

Figure 2.6.2 shows the dependence of jitter on recording power at various recording speeds up to 216Mbps for a 25GB capacity. The jitter value was less than 6.5% with low recording power (5.5mW) even at the user recording rate of 144 Mbps, corresponding to 4 times the basic recording rate of 36Mbps. Even for a 216Mbps data transfer rate, jitter of 7% can be obtained.



Bit length: 112 nm (25GB)

With cross talk After Limit-Equalizer.

Figure 2.6.2 Dependence of the jitter on the recording power (Single Layer disc)

Usually, recording power is directly proportional to recording speed with higher recording powers required as the recording speed increases. However, the available maximum power is limited by the maximum power of current blue violet laser diode. Blu-ray™ Recordable addresses this issue through the combination of variable write strategies and the use of highly sensitive, inorganic write-once materials. The results obtained in Fig. 2.6.2 were achieved using the write pulse strategy for high-speed recording and adjusting the multi-pulse width and bias power level.

An OPC/Test Zone at the inner radius of the BD-R disc enables drives to perform recording tests and/or Optimum Power Calibrations (OPC).

Also a Drive Calibration Zone (DCZ) is included at the outer radius of the BD-R disc. The DCZ is intended for optional drive calibration purposes. For example, the DCZ can facilitate higher speed recording at the outer radius.

White Paper Blu-ray Disc™ Format BD-R

2. Recording and Playback Technologies

In addition to higher recording speeds, large capacity is also achieved for Blu-ray™ Recordable using Dual Layer media. Examples of different recording stacks of Dual Layer media are shown in Fig. 2.6.3.

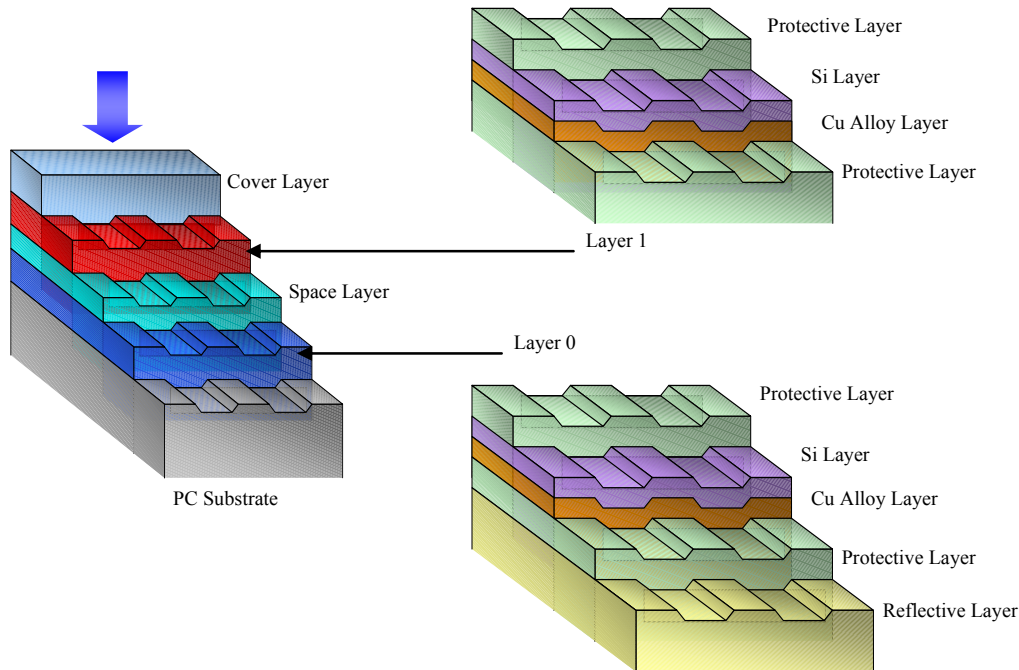
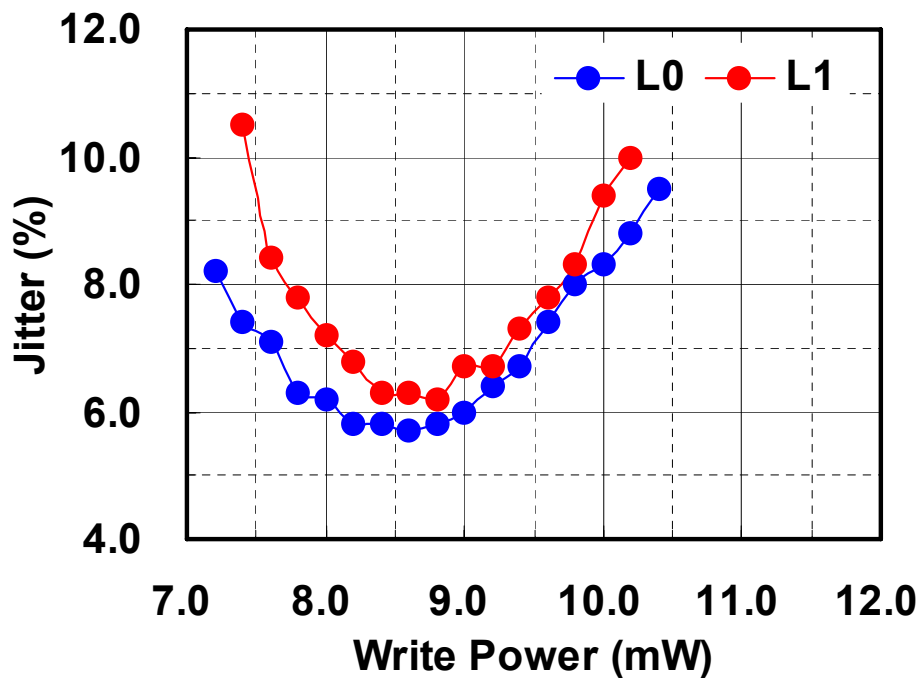
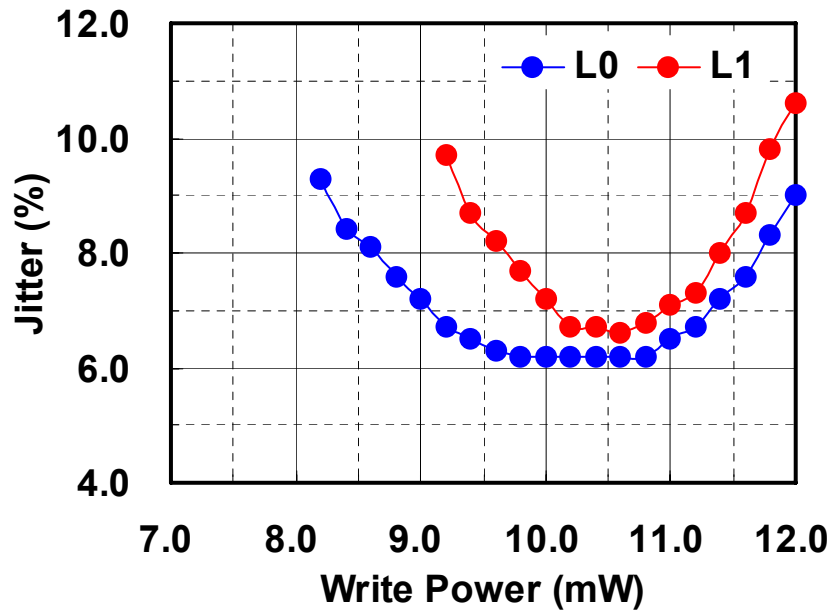

Figure 2.6.3 Cross section of TDK's Dual Layer BD-R disc.

Figure 2.6.4 shows the dependence of power and jitter on the recording rate from 36Mbps to 144Mbps. The jitter value was less than 7% even at the user recording rate of 144 Mbps.



Bit length: 112 nm (50GB)
Speed: 36Mbps (1x)
With cross talk After Limit-Equalizer



Bit length: 112 nm (50GB)

Speed: 72Mbps (2x)

With cross talk After Limit-Equalizer.

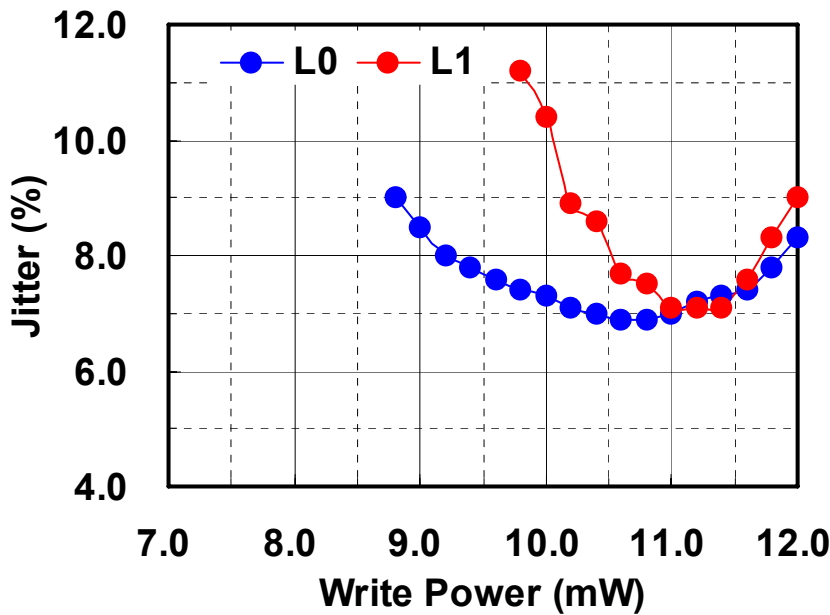

Bit length: 112 nm (50GB)

Speed: 144Mbps (4x)

With cross talk After Limit-Equalizer.

Figure 2.6.4 Dependence of the jitter both on the recording power and recording speed (Dual Layer disc)

2. Recording and Playback Technologies

As previously stated, the N/2 write strategy improves write quality at higher recording speeds. Fig. 2.6.5 shows measurement results comparing the N-1 writing strategy and N/2 writing strategy using organic materials recorded at 72 Mbps (2X). In Fig. 2.6.5, the recording power versus jitter is shown with the results of Conventional Equalizer and Limit-Equalizer. These results demonstrate wider power margins using the N/2 write strategy compared to the N-1 write strategy.

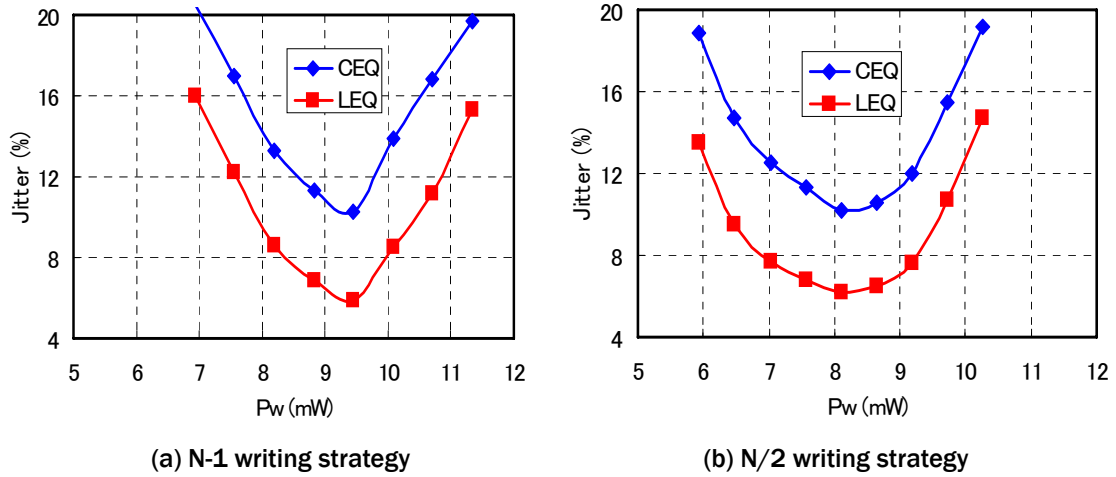

Figure 2.6.5 Dependence of the jitter on the recording power, writing strategy, and read equalizer

3. BDXL™ Technologies

BDXL™ technologies were developed to store a huge capacity of data in order to meet a rapidly increasing demand for both professional usage and consumer production. In Blu-ray Disc™ Recordable Format (BDXL™) format both TL of 100GB capacity and QL of 128GB capacity were defined reflecting conventional media manufacturing technologies. In this chapter the following items are described, main parameters, disc structure, Write Strategy and Extended Adaptive Mark Compensation and i-MLSE (Integrated-Maximum-Likelihood-Sequence-Error-Estimation Technology).

3.1. Main Parameters

Table 3.1.1. shows the main parameters of BD-R, including for both TL of 100GB capacity and QL of 128GB capacity format, main difference with legacy format are cover layer thickness distribution, capacity per layer, minimum Mark length and evaluation index for signal quality. For both TL and QL 2X and 4X recording of 72~144Mbps user transfer rate are specified.

	BD-R			
	SL	DL	TL	QL
Capacity	25 GB	50 GB	100 GB	128 GB
Wavelength of LD	405 nm			
N.A. of objective lens	0.85			
Cover Layer thickness	100µm	100µm (L0) 75µm (L1)	100µm (L0) 75µm (L1) 57µm (L2)	100µm (L0) 84.5µm (L1) 65µm (L2) 53.5µm (L3)
Capacity per layer	25GB	25GB	33.3GB	32GB
Track format	On-Groove			
Address method	MSK (Minimum Sequence Keying) & STW (Saw Tooth Wobble)			
Rotation	CLV			
Track Pitch	0.32µm			
Channel modulation	17PP			
Minimum Mark length	149nm		112nm	117nm
Total efficiency	81.7%			
User Data transfer rate	36 - 216Mbps		72 - 144Mbps	
Signal quality evaluation index	Limit-Equalizer jitter		i-MLSE using PR(1,2,2,2,1)	
Write speed for media	1x, 2x, 4x (Optional), 6x (Optional)		2x, 4x	

Table 3.1.1 Main parameters

3.2. Disc Structure

The disc structures of BD-R TL (Triple Layer)/QL (Quadruple Layer) discs are decided taking account of the following conditions;

- To keep the basic concept of Blu-ray Disc™ format.
- Cover Layer should be as thick as possible to be durable against dust, scratch and finger prints.

Figure 3.2.1 shows an example of disc structure of a TL and a QL disc. The distance between Layer 0 (L0) and disc surface is 100 µm. It is the same as Single Layer (SL) and Dual Layer (DL) discs. The nominal thickness of Cover Layers and Space Layers are shown in this figure. These disc structures were decided paying attention to the two kinds of optical interferences suggested by above constraints.

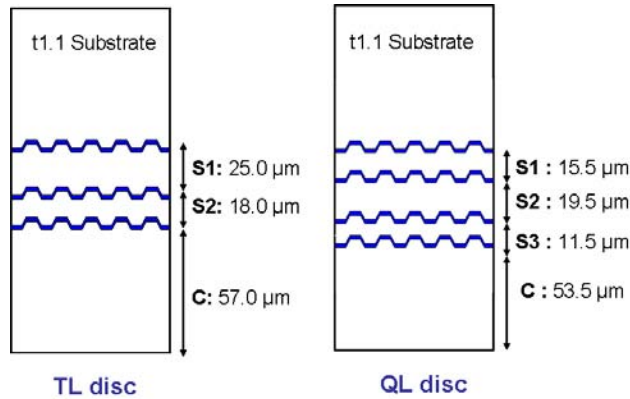

Figure 3.2.1 Disc structure of a TL and a QL discs.

Two optical interferences become more and more crucial for determining the disc structure of Multi-Layer (ML) discs as the number of the layers increases.

The first one to be considered is the optical crosstalk from adjacent layers that is shown in Figure 3.2.2. Figure 3.2.3 shows dependence of the bit error rate (bER) on the Space Layer thickness (S1).

The bER becomes worse when the Space Layer thickness is less than 10 μm. This phenomenon is caused by the crosstalk between the main signals and signals from adjacent layers. Therefore, the Space Layer thickness must be more than 10 μm to avoid deterioration of the readout signal caused by the optical crosstalk from adjacent layers.

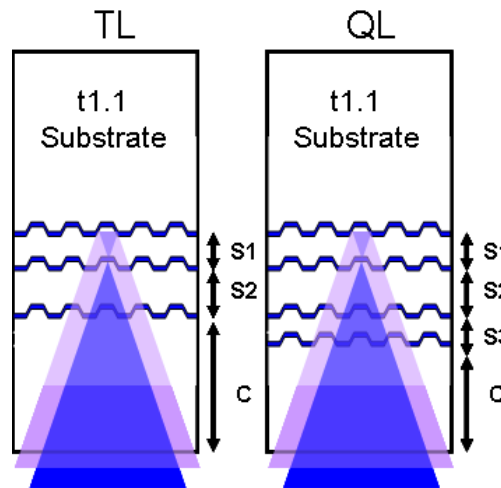

Figure 3.2.2 Crosstalk from adjacent layers

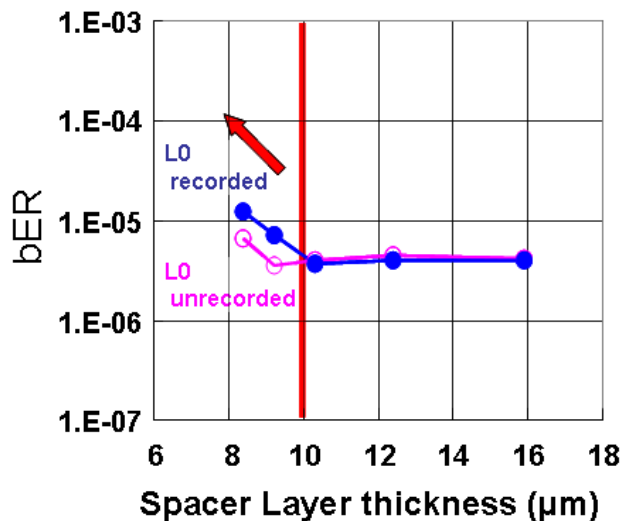

Figure 3.2.3 Bit error rate dependence of Space Layer thickness.

The second one is the optical inter-layer interference. Figure 3.2.4 shows the influence of optical path difference between the main signal light and uninvited three-times-reflected signal light. Red dotted lines show the three-times-reflected lights. These lights are very weak. But once they focus on the photo detector, they interfere with the main signal. Figure 3.2.5 shows the influence of the difference in the thickness between Space Layer (S1) and Space Layer (S2) on the readout signal. The disturbances are observed in the readout signal when the difference in the thickness of S1 and S2 becomes less than 1 μm. This optical inter-layer interference occurs in any combination of thickness differences among Cover Layer and Spacer Layers.

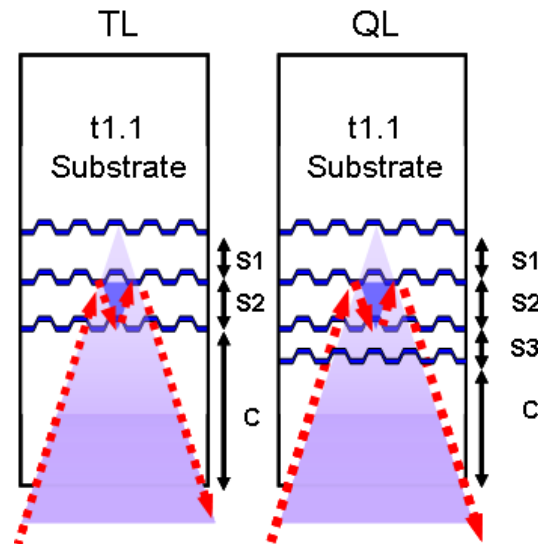

Figure 3.2.4 Optical inter-layer interference.

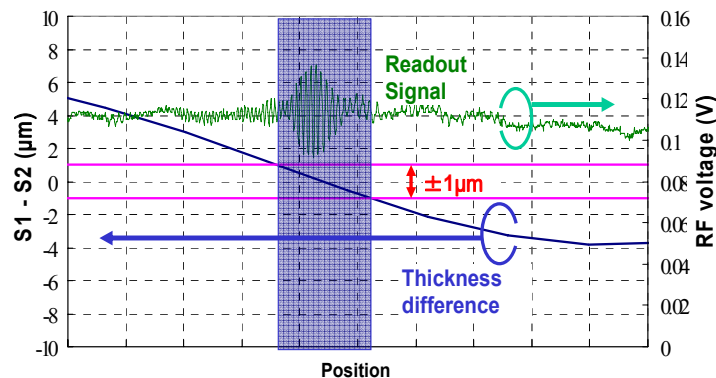

Figure 3.2.5 Influence of optical path difference between the signal light and three-times-reflected signal light on readout signal.

Judging from above experimental results and presupposition of keeping basic concept of Blu-ray Disc™ format, disc structure of TL/QL discs are determined as follows;

- Total thickness of Cover Layer and Spacer Layers shall be 100 μm
- Thickness of Spacer Layers shall be more than 10 μm
- Differences in thickness among Spacer Layers and Cover Layer shall be more than 1 μm
- Thickness of Cover Layer should be as thick as possible so that above conditions are fulfilled

The examples of disc structure shown in Figure 3.2.1 fulfils above conditions.

3.3. Extended Adaptive Write Strategy

Two types of Write Strategies are defined in the Blu-ray Disc™ Recordable format (BDXL™);

Extended N-1 Write Strategy and Extended Castle Write Strategy are applied for the discs. These Write Strategies are based on N-1 Write Strategy and Castle Write Strategy respectively. As the recording density of BDXL™ is higher, a Mark/Space variation matrix is extended to 4 Marks x 4 Spaces to cancel Inter-Symbol Interference between Recording Marks. And Space adaptive parameters are expanded from only preceding Spaces to preceding and succeeding Spaces.

In accordance with the characteristics of each Recording Layer of a disc, a disc manufacturer determines the Write Strategy parameters and embeds them in the HF modulated Groove Area and the Wobbled Groove Address of the disc.

3.3.1 Extended N-1 Write Strategy

Fig. 3.3.1.1 schematically shows Extended N-1 Write Strategy which comprises pulse-modulated recording waveforms with four power levels of P_W , P_{BW} , P_C and P_S . T_{top} denotes the duration of the first pulse, dT_{top} the start time offset of the first pulse from its reference position, T_{MP} the duration of all following pulses except the last pulse, T_{LP} the duration of the last pulse, dT_{LP} the start time offset of the last pulse and dT_S the start time offset of the Space level from its reference position. dT_{LP} is added to control a trailing Mark edge position more precisely. The other parameters are the same as conventional N-1 Write Strategy. Fig. 3.3.1.1 shows an example of the write pulse waveform of a 4T Mark. The write pulse offsets (dT_{top} , dT_{LP} and dT_S), the write pulse duration (T_{top} , T_{MP} and T_{LP}) and the power levels (P_W , P_{BW} , P_C and P_S) are shown. To control Mark edge positions precisely, each parameter (dT_{top} , T_{top} , T_{MP} , dT_{LP} , T_{LP} or dT_S) is defined in $1/16$ of the channel clock resolution.

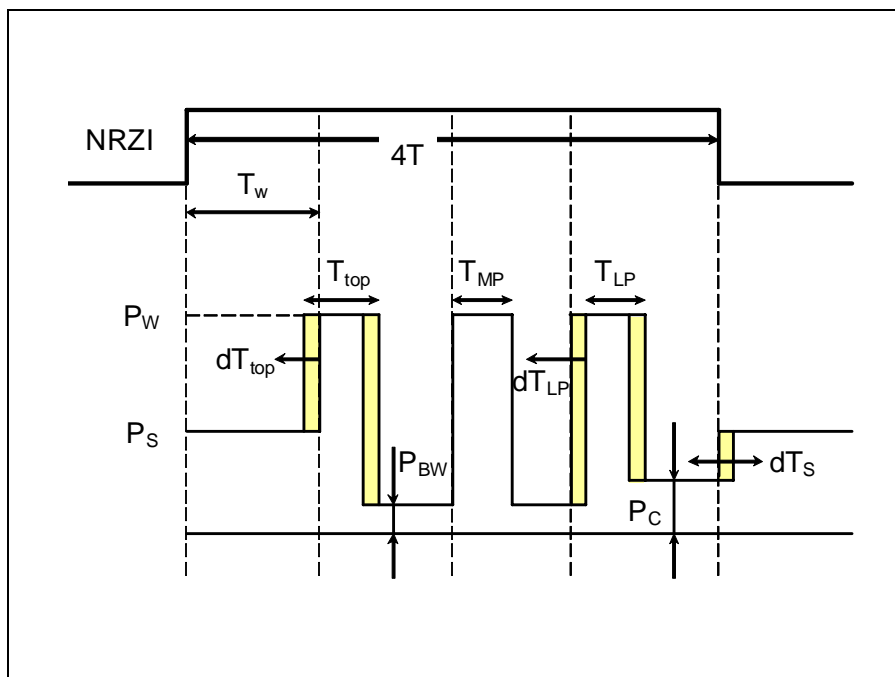

Fig. 3.3.1.1 Extended N-1 Write Strategy

3.3.2 Extended Castle Write Strategy

Fig. 3.3.2.1 schematically shows the Extended Castle Write Strategy which comprises pulse-modulated recording waveforms with four power levels of P_W , P_M , P_C and P_S . All parameters are the same as conventional Castle Write Strategy. T_{top} denotes the duration of the first pulse, dT_{top} the start time offset of the first pulse from its reference position, dT_C the start time offset of the cooling pulse except the 2T write pulse, T_{LP} the duration of the last pulse, and dT_S the start time offset of the Space level from its reference position. Fig.3.3.2.1 shows an example of the write pulse waveform of 6T Mark. The write pulse offsets (dT_{top} , dT_C and dT_S), the write pulse duration (T_{top} and T_{LP}), and the power levels (P_W , P_M , P_C and P_S) are shown. To control Mark edge positions precisely, each parameter (dT_{top} , T_{top} , dT_C , T_{LP} or dT_S) is defined by $1/16$ of the channel clock resolution.

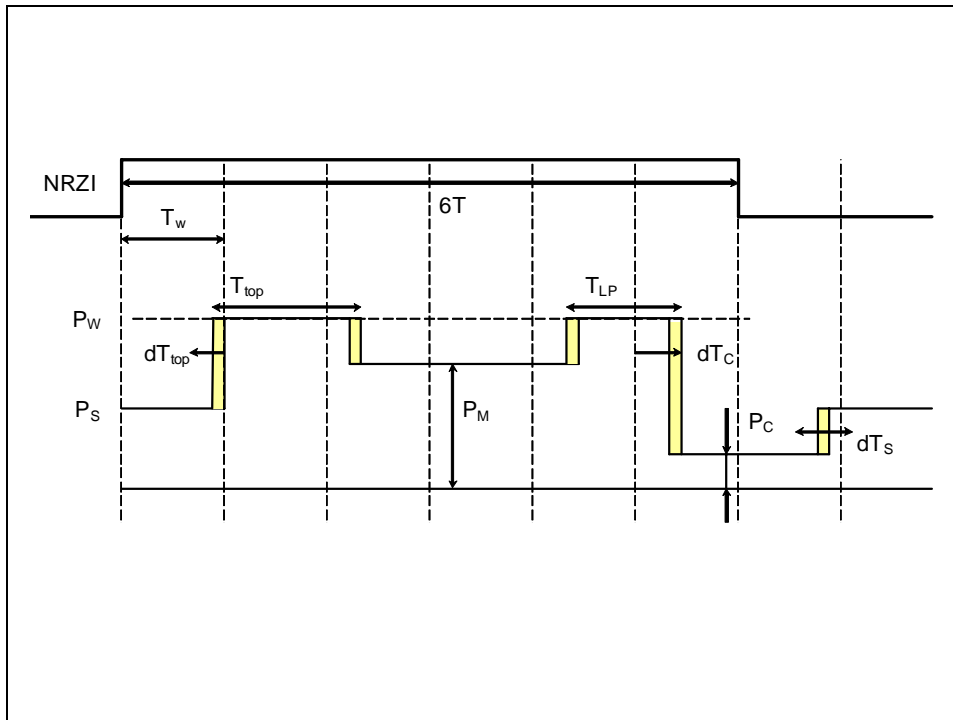
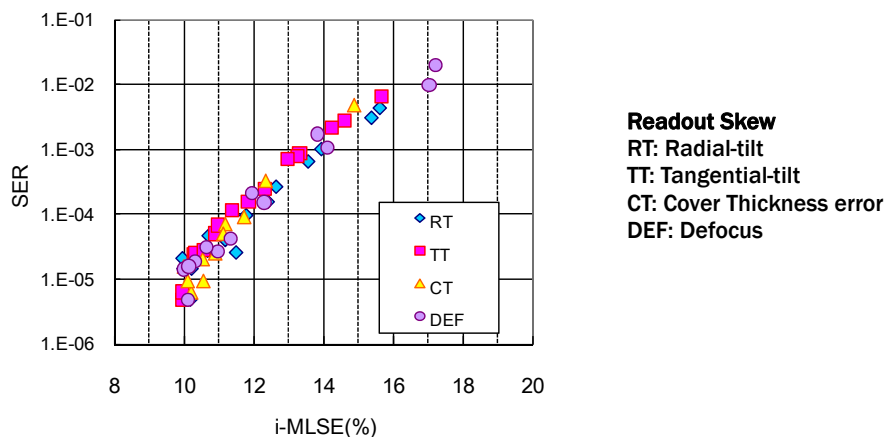

Fig. 3.3.2.1 Castle Write Strategy

3.4. I-MLSE Technology

Introduction

In Blu-ray Disc™ Recordable Format (BDXL™) the capacity per layer is raised up to 33.4GB or 32.0GB only by increasing the linear density. As a result, in BDXL™, the Inter-Symbol-Interference (ISI) of the readout signal becomes much stronger compared to the prior format that allows just 25GB per layer. Therefore the readout signal processing needs to be improved. Also, the prior signal quality evaluation method using the Limit-Equalizer technology has turned out to be no longer applicable. Integrated-Maximum-Likelihood –Sequence-Error-Estimation (i-MLSE), which is an alternative signal quality evaluation method for BDXL™, was newly developed and retains the stability and the precision in such a severe ISI condition of BDXL™. The evaluation method of i-MLSE stands on the detection principle of the Viterbi-Algorithm (VA) in the Partial-Response-Maximum-Likelihood (PRML) readout signal processing. Additionally, some contrivances can be incorporated to achieve the better correlation with the Symbol-Error-Rate (SER). For example, the tendency of error occurrences with the PR(1,2,2,2,1)ML readout in the BDXL™ is considered. Another feature of i-MLSE is that the mathematical expression is the same as that of Time-Interval-Jitter (TI-Jitter or Jitter, simply), which is the prior signal quality evaluation method. Consequently, the behavior of i-MLSE is very similar to that of the TI-Jitter. This helps people who evaluate the BDXL™ discs or systems for the first time to comprehend the meaning of measured values obtained through i-MLSE because the TI-Jitter has been used so long since the era of CDs and is very familiar to them.



This figure shows measurement results of i-MLSE and SER for BDXL™ discs under various kinds of readout conditions. All plots including different kinds of readout conditions are approximately on the same curve. In other words, well-matched correlation performance of i-MLSE is demonstrated here.

Figure 3.4.1: i-MLSE and SER correlation

Basic theory of I-MLSE

i-MLSE is calculated from Sequenced-Amplitude-Margin (SAM) that indicates the reliability of VA. SAM is an instantaneous value that is defined as the path-metric differences between the Maximum-Likelihood-path (ML-path: decoded result in VA) and the Second-Likelihood-path (2nd-path) as shown in the left side figure of Fig 3.4.2. In VA the path that has the smallest path-metric survives as the more-likelihood path at every state to which several branches are inflowing, as shown in the right side trellis diagram of Fig. 3.4.2. Therefore, the detection reliability of VA can be quantified by how smaller the path-metric of the ML-path compared to the rivalry paths' path-metric, in other words, how large the SAM value is.

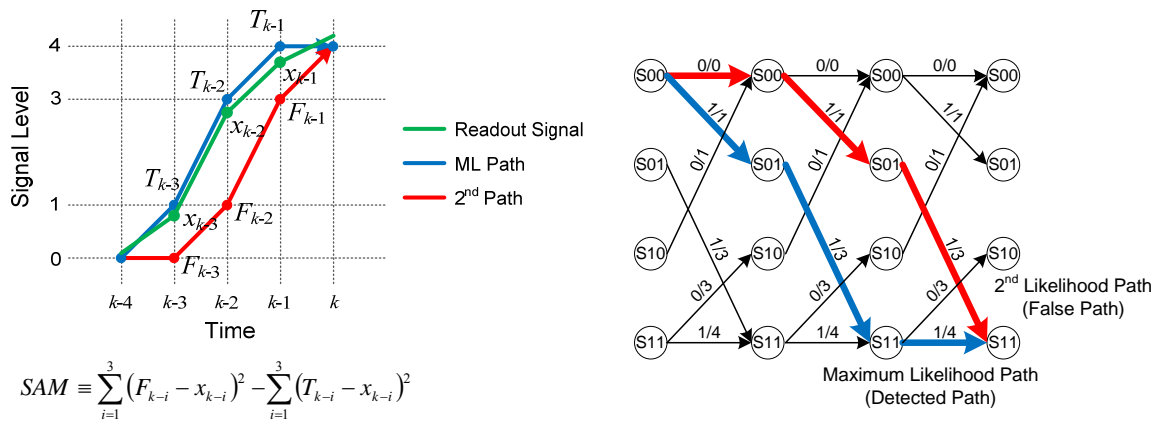

Left figure shows how to calculate the SAM value and right figure shows the trellis diagram of VA. Although PR(1,2,2,2,1)ML with d=1 run-length limited (i.e., ten states) is employed in the BDXL™ specification, simpler PR(1,2,1)ML with d=1 run-length limited (i.e., four states) is assumed in these figures for ease of understanding of the concept of SAM.

Figure 3.4.2: Calculation of the SAM value

Generally, readout waveforms are distributed around ideal waveforms (i.e., ML-paths). In these cases, the distribution of SAM values is revealed to be approximately a normal distribution which means SAM value is almost equal to the square Euclidean distance between ML-path and 2nd-path. By fitting the SAM distribution to the normal distribution we can calculate the error rate from the probability of appearance of the region in which SAM<0. If the SAM distribution can be approximated as a single normal distribution from the viewpoint of prediction of error occurrences, the evaluated value of i-MLSE can be defined in completely the same manner as in the prior TI-Jitter. But actually, there are several error-dominant patterns which have different Euclidean distances and different variances (i.e. plural different normal distributions) in BDXL™. Therefore, to quantify the signal quality by a single value, it is required to evaluate contributions of the estimated errors from plural distributions with different variance and different mean value. In i-MLSE three groups of error-patterns are evaluated as error-dominant patterns as shown in the Table 3.4.1.

Group Name	Group 14	Group 12A	Group 12B
Error Mode	One bit shift	Single 2T shift	Consecutive 2T shift
Euclidean Distance (d _k)	$\sqrt{14}$	$\sqrt{12}$	$\sqrt{12}$
Truth and Error Bit Pattern (example)	T: 000001111 E: 000011111	T: 00000110000 E: 00001100000	T: 0000011001111 E: 0000110011111

Table 4.4.1 Evaluating error-patterns of i-MLSE

Calculation of i-MLSE

For simplifying the numerical expression, we define normalized-SAM (ξ_k) for SAM of the k-th error-pattern as follows;

$$\xi_k \equiv \frac{SAM_k - d_k^2}{2d_k^2} \quad (3.4.1)$$

, where d_k^2 represents the square Euclidean distance of the k-th error-pattern.

i-MLSE is calculated in the following three steps. In the first place, for the purpose of quantifying the quality

3. BDXL™ Technologies

of the signal, mean value (η_k) of the minus side of ξ_k distribution with respect to its mean value (μ_k) is calculated (Fig.3.4.3). Under the assumption of the normal distribution for ξ_k , the estimated bER of the k-th error-pattern ($ebER_k$) and η_k has the relationship as follows;

$$ebER_k = \frac{\rho_k W_k}{2} \operatorname{erfc} \left(\frac{1 + 2\mu_k}{2\sqrt{\pi}(\mu_k - \eta_k)} \right) \quad (3.4.2)$$

, where ρ_k denotes the frequency of the k-th error-pattern, W_k denotes the Hamming distance of the k-th error-pattern and $\operatorname{erfc}(\cdot)$ denotes the complimentary error function. Then, the total estimated bER ($ebER_{\text{total}}$) is obtained by adding each $ebER_k$ for all error-patterns. This manner is very straightforward, but the integration among the different error-patterns can be performed most accurately. Finally, i-MLSE ($\sigma_{i\text{-MLSE}}$) is obtained by converting $ebER_{\text{total}}$ to the equivalent normalized standard deviation (i.e. the jitter value) by following equation;

$$\sigma_{i\text{-MLSE}} \equiv \left\{ 2\sqrt{2} \operatorname{erfc}^{-1} \left(\frac{2 \cdot e \text{ bER}_{\text{total}}}{\rho_{\text{total}}} \right) \right\}^{-1} \Leftrightarrow e \text{ bER}_{\text{total}} = \frac{\rho_{\text{total}}}{2} \operatorname{erfc} \left(\frac{1}{2\sqrt{2} \sigma_{i\text{-MLSE}}} \right) \quad (3.4.3)$$

, where $\operatorname{erfc}^{-1}(\cdot)$ denotes the operation of the invert function of the complimentary error function.

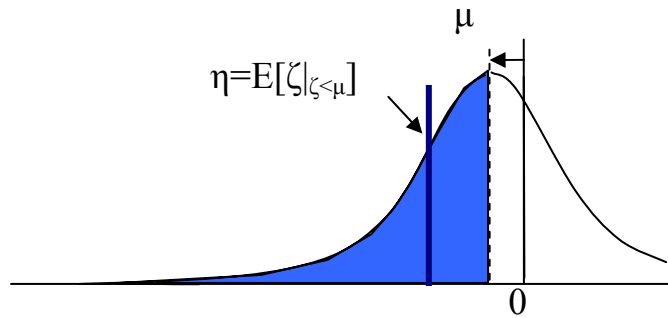

Fig.3.4.3: Signal quality estimation by the one-sided mean value of the normalized SAM distribution

4. Modulation Code and Error Correction Code for Blu-ray Disc™(BD)

4.1. Modulation Code

What is a Modulation Code?

Modulation codes are one of the key elements in optical storage systems such as CD, DVD or BD. In a digital storage system (Fig. 4.1.1), two parts can be distinguished; the transmitting part, including the write-channel in which a user stores data on the disc, and the receiving part, including the read-channel which aims to restore the original information by reading out the data written on the disc.

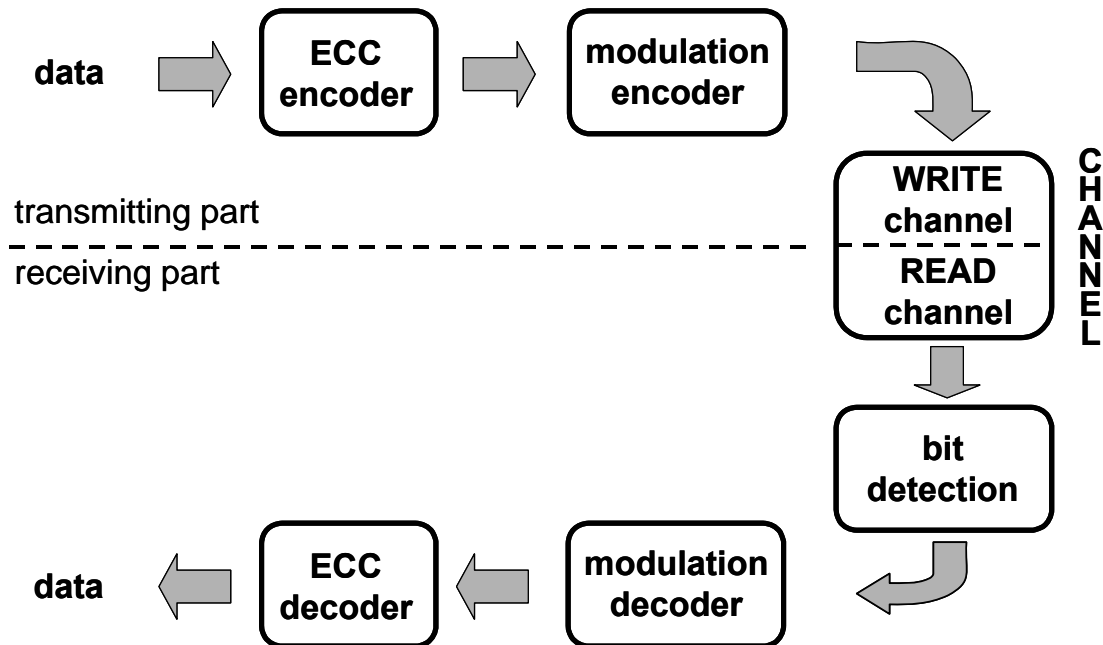

Figure 4.1.1: Schematic form of a digital storage system.

In order to realize a sufficiently high level of reliability, the data is first encoded before being stored. This typically comprises an Error-Correcting Code (ECC) and a Modulation Code. The channel encoder at the transmitting end consists of the ECC-encoder and the modulation-encoder. At the receiving end of the channel, there is the physical signal detection with the read head scanning the information on the disc, followed by the bit-detection module, which aims to derive the written bits (also called *channel bits*) from the measured signals as reliably as possible. These blocks precede the channel decoding, which comprises first the modulation-decoder, followed by the ECC-decoder.

The ECC adds redundancy in the form of parity symbols, which makes it possible to restore the correct information in the presence of channel imperfections like random errors and/or burst errors that may occur during read-out from the disc. The modulation code serves to transform arbitrary binary sequences into sequences that possess certain "desirable" properties. A very convenient property is that the stored sequences contain neither very short nor very long runs of successive zeros or ones. The reason for this originates in how a stored sequence is read from the storage medium.

In optical recording, the modulation of the physical signals is determined by two different physical states of the disc; the physical states being associated with two different levels of reflectivity (high and low) of the Marks (or *Pits*) and Spaces (or *Lands*). One physical state can be associated with channel bit "1", the other with bit "0". This representation is commonly known as NRZI (Non-Return to Zero Invert). An equivalent representation of a channel bitstream is the NRZ (Non-Return to Zero) notation, where a "1"-bit indicates the start of a new Mark or Space, and a "0"-bit indicates the continuation of a Mark or Space. An NRZI channel bitstream can be partitioned into a sequence of *runs*, where each run consists of a number of consecutive channel bits of the same type. The number of bits in a run is called the *runlength*. A small part of a Track on the disc is shown in Fig. 4.1.2. Along the Track, physical Marks and Spaces alternate with

their lengths being multiples of the channel bit length T .

Very short runs lead to small signal amplitudes in the read-out by the physical detection system and are therefore more prone to errors in the bit-detection module. Moreover, very long runs lead to inaccuracies in the *timing recovery*, which is dealt with by a *Phase-Lock Loop (PLL)*. The PLL regenerates the internal bit "clock" by adjusting it at each transition. Areas on the disc with too few transitions may cause "clock-drift". Avoiding very short and/or very long runs is achieved by using a *RunLength-Limited (RLL)* code, which constrains the allowable minimum and maximum runlengths that occur in the channel bitstream. The RLL constraints are described in terms of two parameters, d and k : the minimum and maximum runlengths are equal to $d+1$ and $k+1$. For the *uncoded* case, $d=0$ and $k=\infty$. In NRZ notation, a run of length $m+1$ is represented by a "1"-bit followed by m "0"-bits. Hence the (d,k) -constraint in NRZ notation requires that the number of "0"-bits between two successive "1"-bits is at least d and at most k . Most RLL codes are constructed in NRZ notation. Subsequent transformation from NRZ to NRZI yields the channel bits that are actually written on the disc. This is done by a so-called 1T-precoder, which is an integrator modulo 2 (Fig. 4.1.2). Since the RLL constraints forbid certain specific patterns, it follows that a sequence of source bits must be translated into a longer sequence of channel bits; the ratio of the length of the original and encoded sequences is called the *rate* of the code.

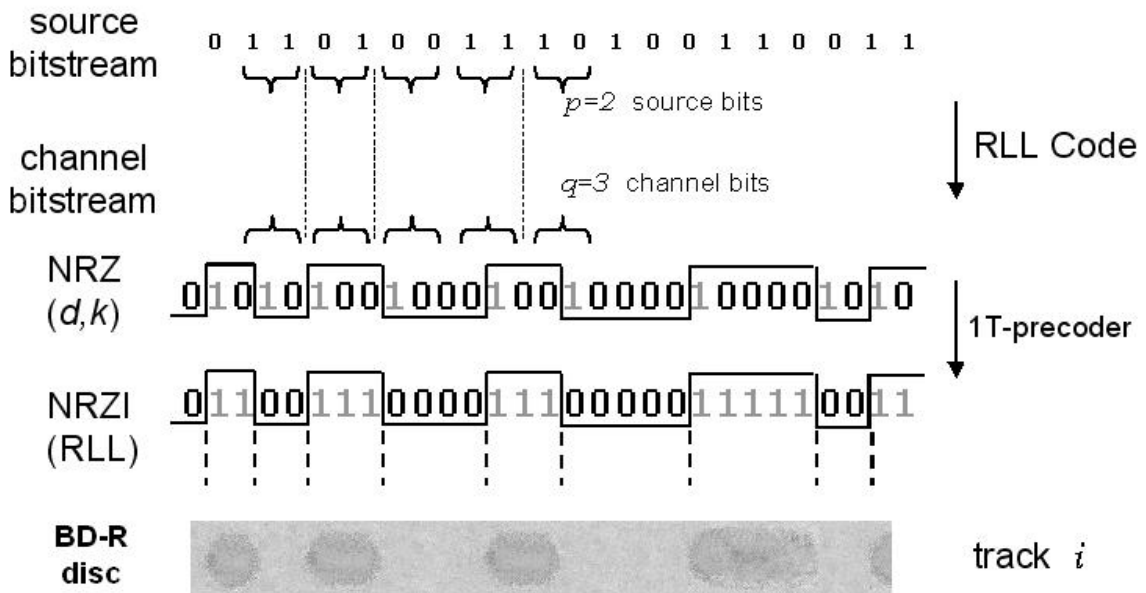

Figure 4.1.2: RLL $d=1$ coding for BD optical recording.

Why $d=1$ Constraint for BD ?

High-capacity storage applications like BD employ such small bit sizes that the signal waveform generated by the physical detection system for a given bit location does not only depend on that single bit, but also on a limited number of neighboring bits. This bit-smearing effect is better known as *Inter-Symbol-Interference (ISI)*. The ISI is characterized by the impulse response of the channel, or, equivalently, by its Fourier transform which is known as the *Modulation Transfer Function (MTF)* of the channel. The MTF indicates the response of the channel for each frequency in the system.

In optical recording, the MTF has an almost linear roll-off up to the cut-off frequency of the channel (Fig. 4.1.3).

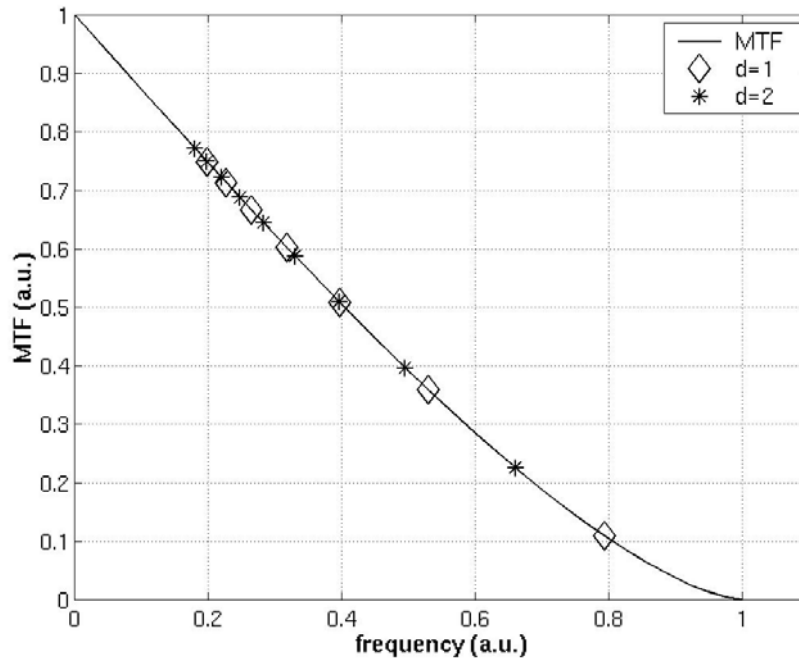

Figure 4.1.3: MTF for the optical recording channel as a function of frequency (in arbitrary units, with the cut-off at “1”) with the frequencies of the pure tones ... | nT_d | nT_d | ... superimposed.

Therefore, short runlengths in the channel bitstream, which lead to high-frequency signals, suffer most from ISI and are thus more prone to errors during read-out. One of the purposes of runlength-limited coding is to impose constraints that do not allow these high-frequent bit-sequences. To illustrate this principle, we discuss the effect of employing three different d -constraints, for $d=0$ (uncoded), $d=1$, and $d=2$, while maintaining the same density of *source* bits on the disc. So let T denote the common physical size of a source bit. Using a d -constrained code at a rate R_d , the physical channel bit size T_d will necessarily satisfy $T_d = R_d T$. Fig. 3.1.4 shows the respective channel bit lengths and the highest frequency in the system (which correspond to an alternation of runs of minimum runlength). Here, we of course have $R_0=1$ in the uncoded case. Furthermore, we assume that practical codes are used that have rates $R_1=2/3$ and $R_2=1/2$, which are close to the maximal achievable code rates of 0.6942 and 0.5515, respectively. The minimum runlength for $d=1$ equals $2T_1=4/3T$, which is larger than the minimum runlength T for $d=0$; also, the minimum runlength for $d=2$ amounts to $3T_2 = 3/2T$, which is larger than the minimum runlength for $d=1$. Consequently, the highest frequencies f_d in the system are

$$f_0 = \frac{1}{2T} > f_1 = \frac{1}{4R_1T} = \frac{3}{8T} > f_2 = \frac{1}{6R_2T} = \frac{1}{3T}.$$

This relation reveals the increasing low-pass character of the code for increasing d constraint, which is the major attractiveness of RLL coding. This becomes also clear from Fig. 3.1.3, which shows the MTF with the frequencies of the pure tones ... | nT_d | nT_d | nT_d | ... for $n=d+1, d+2, \dots$ superimposed.

However, note that the Channel bit length (or *timing window*) decreases for increasing d constraint, which leads to a greater sensitivity with respect to *jitter* or *Mark-edge noise* in the system. This counteracting effect favors the use of a *lower* d constraint. The practical choice for the $d=1$ constraint in BD is the optimal compromise between mark-edge noise (lower d) and ISI (higher d). The k -constraint has been chosen to be $k=7$, from which the acronym “17PP” has been derived.

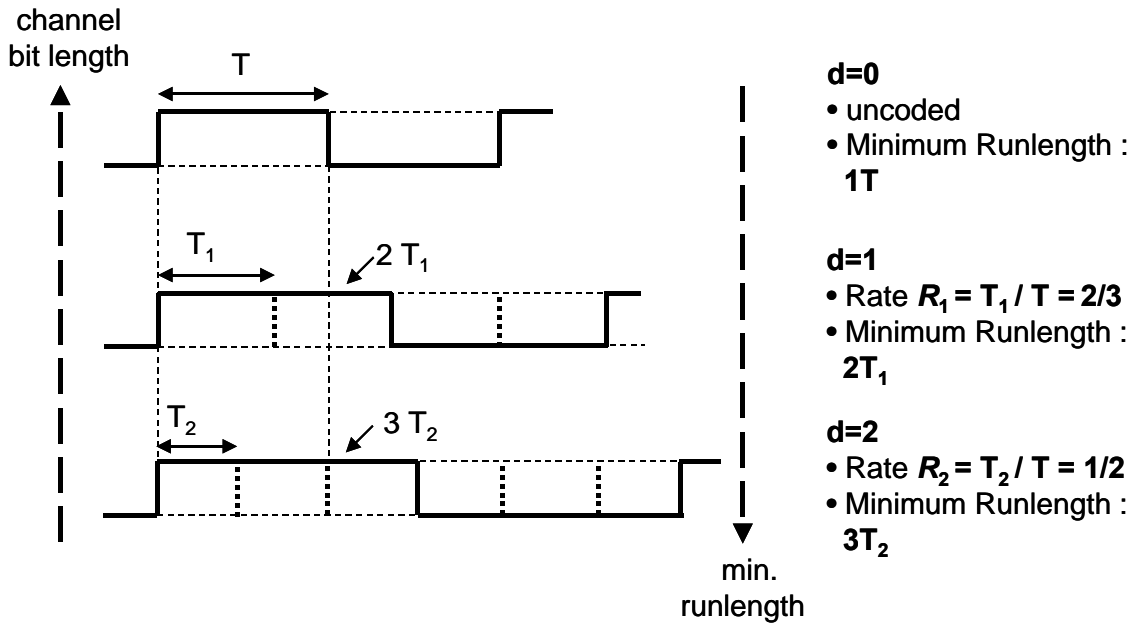

Figure 4.1.4 Channel bit length and minimum runlength for different d constraints at the same recording capacity.

Why 17PP “Parity-Preserving” Code?

All RLL codes used in optical recording are *DC-free*, that is, they have almost no content at low frequencies. We consider NRZI Channel bits b_i with bipolar values ± 1 . A sequence b_1, b_2, \dots is called *DC-free* if its *Running Digital Sum* (RDS; the integral of the bipolar Channel bitstream)

$$RDS_i = \sum_{j=-\infty}^i b_j$$

takes on only a limited number of different values. Then, the power spectral density function vanishes at DC. The DC-free property is needed for a number of reasons; (i) for separation of the data signal from disc noise such as fingerprints or dust, (ii) for control of the slicer level, and (iii) for the servo systems.

We shall now discuss a general method to achieve DC-control in RLL sequences. DC-control is performed via control of the Running Digital Sum (RDS). A very useful concept herein is the *parity*, the number of ones modulo 2, of a sequence of bits. Recall that an NRZ “1”-bit indicates the start of a new run in the (bipolar) NRZI bitstream. Hence, because of the $1T$ -precoder between NRZ and NRZI Channel bitstreams, each “1”-bit in the NRZ bitstream changes the polarity in the corresponding NRZI bitstream. Consequently, an *odd* number of ones in a segment of the NRZ bitstream *reverses* the NRZI polarity after that segment while an *even* number of ones leaves the polarity unchanged.

The above observation can be used for DC-control as follows. Suppose that for a certain segment of the NRZ bitstream, we can choose between two candidate sequences, one with parity “0”, the other with parity “1”. Then the part of the NRZI bitstream *after* this segment will have a contribution to the RDS where the *sign* depends on which of the two sequences is chosen. The *best* choice is of course the one that keeps the value of the RDS as close to zero as possible. We refer to these segments as *DC-control segments*. In order to realize DC-control, we have to insert DC-control segments at regular positions in the bitstream. Such positions are referred to as *DC-control points*.

A clever and efficient method for DC-control, as used in the 17PP modulation code of BD, is via the use of a *Parity-Preserving* code (Fig. 4.1.5). Such a code preserves the parity upon RLL encoding, that is, the parity of a source word is identical to the parity of the corresponding channel word. Single DC-control bits are inserted (at DC-control points) in the *source* bitstream. Changing a DC-control bit from 0 to 1 changes the parity in the source bitstream and hence also in the NRZ Channel bitstream: this property enables the selection of the polarity of the NRZI Channel bitstream, and thus allows for DC-control. The overhead required for each DC-control point in the 17PP code is exactly equal to one source bit, which amounts to the equivalent of 1.5 channel bits. This makes the 17PP Parity-Preserving $d=1$ code 25% more efficient at each DC-control point, compared with conventional methods for DC control.

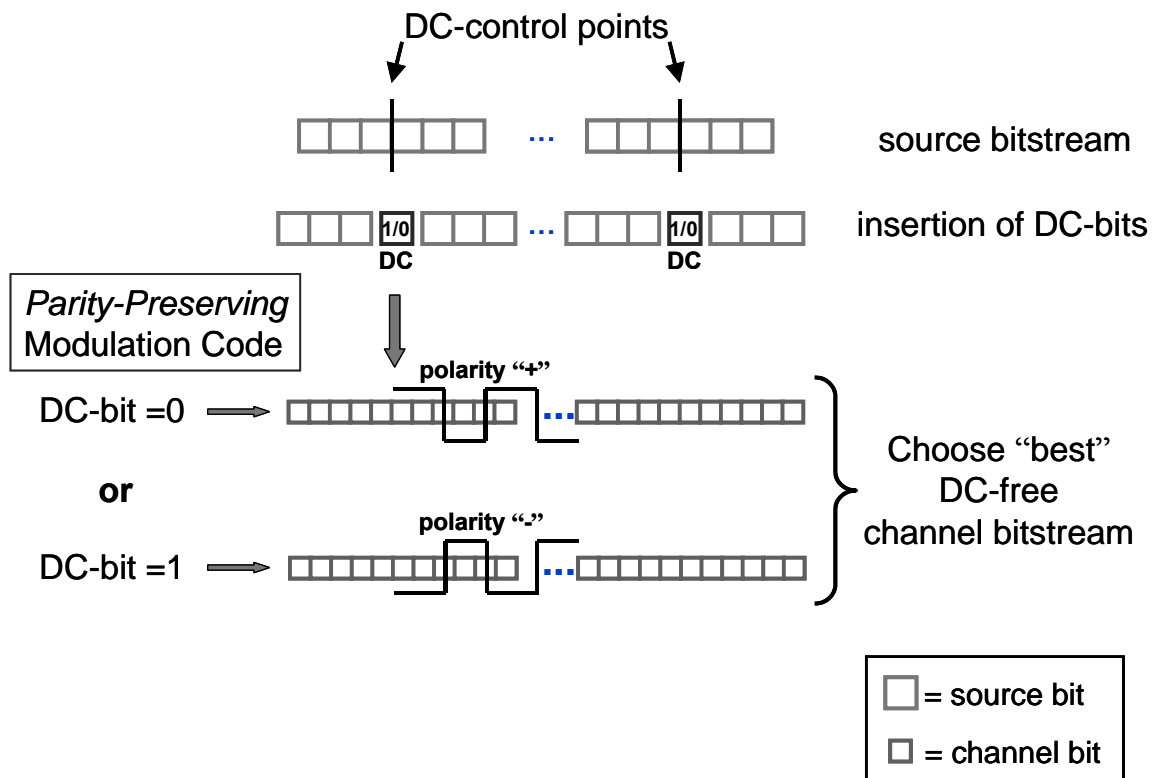

Figure 4.1.5: Principle of DC-control via *Parity-Preserving* modulation code.

The 17PP code has been designed with one additional favorable property in the sense that it prohibits the occurrence of a large number of consecutive minimum runlengths ($2T$) which is known as the RMTR (Repeated Minimum Transition Runlength) constraint. The minimum runlengths lead to low signal levels, and by restricting their occurrence, the read-out performance is improved.

4.2 Error Correction format

In optical recording roughly two types of errors can be distinguished: single (or random) errors and burst errors. Single errors are caused by noise in combination with other sources of signal deterioration such as tilt of the disc or defocus of the laser spot on the disc. They are called single errors because they only affect one or two bytes. Burst errors are caused by defects on the disc surface like scratches, dust, fingerprints etc.

The Error Correction system should be adapted to the physical properties of the medium on which the data is stored. Blu-ray Disc™ is, due to its small spot, the thin cover layer and the high numerical aperture, more sensitive to burst errors than for instance the DVD system. The same defect on a Blu-ray Disc™ will affect more data bits than on a DVD Disc. The error correction system of Blu-ray Disc™ should therefore be able to cope very well with long burst errors.

The maximum number of errors that can be corrected depends on the number of parity symbols added. For each two parity symbols added, one error can be corrected. This assumes nothing is known beforehand about the error. If the location of an error within the code word is known beforehand, only the erased value of the error has to be calculated. For each parity symbol added, one erased value can be calculated, i.e. one erasure can be corrected. So it is advantageous for the Error Corrector to use prior knowledge of the error locations in the decoding process. Due to the nature of the errors, this is not possible for random errors, but it is very well possible for burst errors. It requires a burst indicator mechanism that can detect bursts of errors before the correction starts.

Blu-ray Disc™ uses an Error Correction system with a very efficient method of burst indication - a picket

White Paper Blu-ray Disc™ Format BD-R

4. Modulation Code and Error Correction Code for BD

code. The structure of such a picket code is shown in Fig.4.2.1. The pickets are columns that are inserted in between columns of the Main Data at regular intervals. The Main Data is protected by a Reed Solomon code that is strong and efficient. The pickets are protected by a second, independent and extremely strong Reed Solomon code. When decoding, first the picket columns are corrected. The correction information can be used to estimate the location of possible burst errors in the Main Data. The symbols at these locations can be flagged as erasure when correcting the code words for the Main Data. This strategy of applying erasures is shown in Figure 4.2.1.

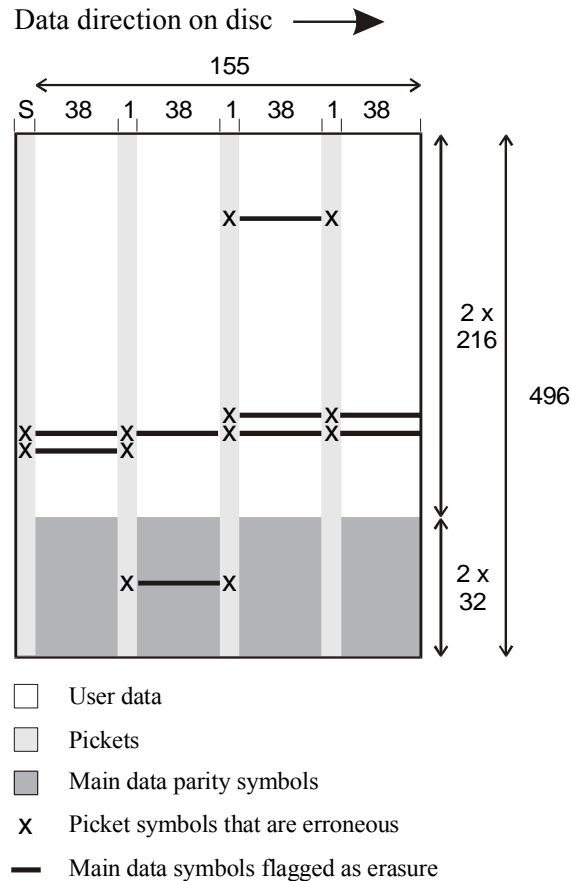

Figure 4.2.1 Schematic representation of the Blu-ray Disc™ picket code

A Blu-ray Disc™ Error Correction Block (ECC Block) can store 64 kilobytes of user data. This data is protected by the so called Long Distance Code (LDC) which has 304 code words with 216 information symbols and 32 parity symbols giving a code word of length 248. These code words are interleaved two by two in the vertical direction such that a block of 152 bytes x 496 bytes is formed as shown in Fig.4.2.1. A Blu-ray Disc™ ECC block contains 4 equally spaced picket columns. The left most picket is formed by the Sync patterns at the start of each row. If the Sync pattern was not detected properly, that can be an indication for a burst error similar to the knowledge that a symbol of a picket column had to be corrected. The other three pickets are protected by the so-called Burst Indicator Subcode (BIS). This BIS-code has code words with 30 information symbols and 32 parity symbols giving a code word length of 62. The BIS code words are interleaved into three columns of 496 bytes each. Note that both LDC code and the BIS code have the same number of parity symbols per code word and therefore only one Reed Solomon decoder is required to decode both codes.

The information symbols of the BIS-code form an additional data channel next to the main data channel. This side-channel in the BIS-columns contains addressing information. The addressing information is protected separately against errors with a Reed Solomon code that has code words with 5 information symbols and 4 parity symbols. This extra code is necessary to allow for fast and robust detection of the addresses, independent of the main ECC.

5. Address Format Using Groove Wobbles

Address Format Using Wobbled Groove

The Blu-ray™ Recordable disc has the exact same address format as that of the Blu-ray™ Rewritable disc. The disc contains a single spiral Wobbled (slight radial deviations from a true spiral) Groove used to perform tracking control and generation of write-timing for the drive. In addition, the Wobbled Groove contains embedded addressing and auxiliary information on the unrecorded Track. The address information identifies Track positions across the entire Grooved Area on the disc while the auxiliary information contains information inherent to the disc. For embedding this information, the Groove of the BD-R is modulated by Wobbling. The amplitude of the Wobble modulation is approximately ± 10 nm in a radial direction of the disc.

The BD-R writes very small high-density Marks with precision. For this reason, the disc drive requires a highly stable and accurate recording clock signal. Therefore, the fundamental frequency component of Wobbles is a single frequency and the Groove is smooth and continuous. Given a single frequency, it is possible to generate a stable writing clock signal with ease from filtered Wobble components. Since User Data is always written in sync with the Wobbles, the length of one Wobble period is always proportional to the Mark length of written data. Thus the disc capacity is naturally determined by the length of the Wobble period formed on the disc. (For example, the capacity of a Single Layer disc is 25.0 GB if the Wobble length is 5.14 μm , and 27.0 GB if the Wobble length is 4.76 μm , corresponding to exactly 69 channel bits per Wobble period.)

Some single frequency-based Wobbles are further modulated in order to provide additional timing and address information. This modulation must be robust against various types of distortion inherent to optical discs. Roughly classified, the following four distortions can occur on optical discs.

- (1) Noise: Groove noise is caused by the recording film and the rough formation of tracking Groove. Data crosstalk noise is caused by recorded data.
- (2) Wobble shift: A phenomenon where the position of Wobble detected by the disc drive relatively shifts from the normal position, resulting in decreased detection sensitivity. The Wobble shift tends to occur immediately after seeking.
- (3) Wobble beat: The Wobble beat is produced by Wobble crosstalk of adjacent Tracks. The cause of the Wobble beat is a shift in angular frequency of adjacent Wobbles in the CLV format.
- (4) Defect: A local flaw such as dust or scratch on disc surface.

A fundamental requirement in the development of the address format of BD was to take measures against all of these different types of distortions. Consequently, BD uses a combination of two different Wobble modulation systems in a configuration producing synergistic effects without adverse side effects. This combination satisfies all the anti-distortion requirements, an outcome that is difficult to achieve using only one modulation system. More specifically, BD has adopted a completely innovative address system combining Minimum-Shift-Keying (MSK) modulation and Saw-Tooth-Wobble (STW) technology, as explained later. The address format making use of MSK and STW is highly stable against the four types of distortion owing to each basic shape of the wobble address format.

Configuration of the ADIP Unit and Wobble Groove Shapes

Groove Wobbles, formed spirally on disc, can be divided into successive units of address information bits embedded in the Wobble, as shown in Fig. 5.1. These are known as the Address In Pre-Groove (ADIP) Unit. One ADIP Unit is comprised of 56 Wobbles. Fig. 5.2 shows a schematic diagram of the ADIP Unit expressing "1" and "0" of one bit in address data by the MSK and STW combination.

White Paper Blu-ray Disc™ Format BD-R

5. Address Format Using Groove Wobbles

Fig. 5.1

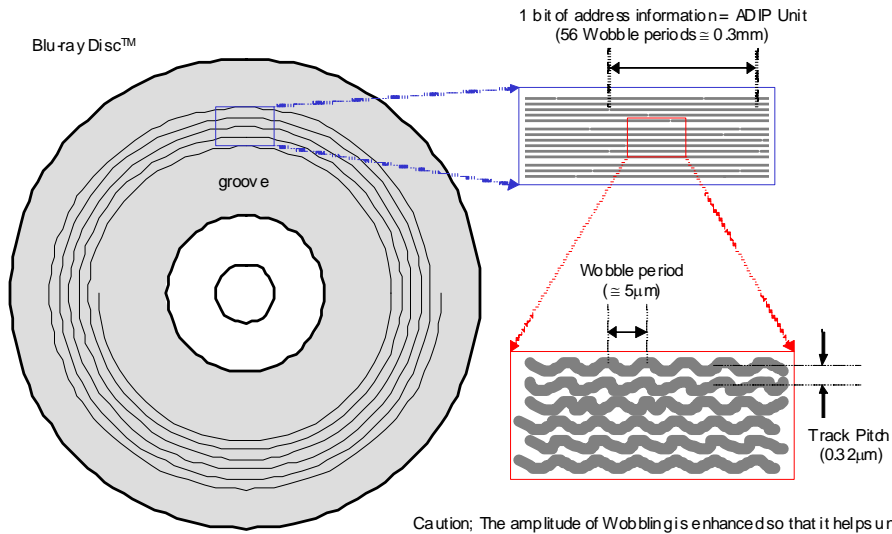

For the tracking of the laser beam, continuous spiral Groove is formed on the disc.
The Groove is modulated with Wobbling by cosine, MSK and STW in order to store the address information.

Fig. 5.2

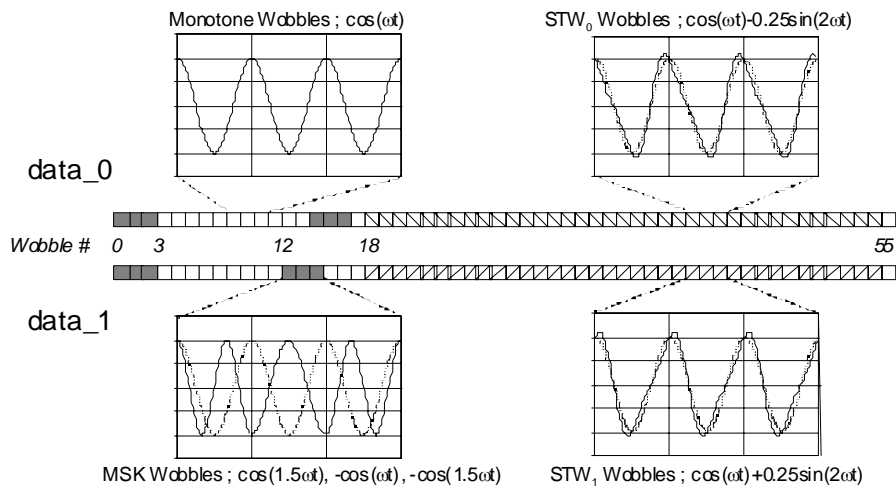

Schematic representation of the ADIP Units for Data_0 and Data_1. An ADIP Unit has a length of 56 Wobbles, which contain the first MSK Mark for bit sync, the second MSK Mark characterized by the difference of the position and 37 STWs characterized by the difference of the slope for Data_0 or Data_1.

The basic Units of MSK and STW have the following shapes. The basic Unit of MSK Wobbles is three Wobbles. The middle Wobble of the three has an inverted polarity in comparison with continuous cosine waves $\cos(\omega t)$ (known as Monotone Wobble) and is sandwiched between cosine waves of a 1.5X frequency, $\cos(1.5 \omega t)$. MSK is made up of cosine instead of sine because, in the MSK modulation using phase inversion, smooth waveform connections will be achieved with adjacent Wobbles without a discontinuous section. As a result, MSK requires a small number of frequency bands. As MSK uses one type of waveform alone, differences in waveform position are used as information.

STW waveforms are classified into two types. The waveform of data 0 has edges that rise steeply towards the outer side of the disc and fall gently towards the inner side of the disc. Conversely, the edges of the waveform of data 1 rise gently and fall steeply. The shape resembles saw teeth and that is why STW was so named. Mathematically, STW is expressed by the addition of the fundamental wave $\cos(\omega t)$ and the second harmonic $\sin(2\omega t)$ with a quarter-amplitude. The polarity of the secondary sine component in the case of data 0 is the inversion of data 1. Characteristically, zero-cross points, as in the case of Monotone Wobbles, have no influence on the clock phase reproduced from the fundamental wave component. Although sharp saw teeth can be expressed by the incorporation of higher harmonic components, the limitation to the secondary component makes it possible to keep the required band narrow for the disc mastering unit and to prevent degradation in high-frequency components caused by other signals.

Every ADIP Unit starts with a MSK, as shown in Fig. 5.2. The starting MSK called "bit sync" serves as an identifier for the ADIP start point. The difference in the position of the next MSK represents 0 or 1 of data. More specifically, there are successive Monotone Wobbles between the bit sync and the second MSK, the number being 11 for data 0 and 9 for data 1, giving a 2-Wobble difference in position. It should be noted that MSK utilizes local phase change of the fundamental wave. In other words, areas of no phase change must be predominant to generate a stable write clock and for Wobble detection. Those areas effectively use STW, for which the phase of the fundamental wave does not change. In an ADIP Unit, 37 Wobbles from the 18th to the 54th are modulated by STW. Wobbles representing data 0 have edges rising steeply, and those representing data 1 have edges rising gently and are provided extensively. In order to ensure increased address reliability, the same information is stored in a single ADIP Unit in different MSK and STW formats.

A series of 83 ADIP Units forms an ADIP word expressing an address. One ADIP word contains 12-bit auxiliary data, reference (explained later), Error Correction Code, as well as 24-bit address information. The BD Wobble format allocates three ADIP words to each 64-Kbyte Recording Unit Block (RUB) of main data for writing.

Detection Methods for and Characteristics of MSK and STW

The BD drive unit detects Wobble signals from Push-Pull signals. Fig. 5.3 shows an example of circuit configuration. The drive unit is allowed to use MSK and STW independently or simultaneously to identify 0 or 1 of an ADIP Unit.

MSK and STW, although apparently different, can be detected using the same heterodyne circuits (consisting of a carrier multiplier, integrator, sample-and-hold, and comparator). Increased detection performance is achieved by a hybrid detection method in which integrals of MSK and STW are accumulated.

Their detection methods differ in that MSK uses the fundamental wave (957 KHz) as the carrier for multiplication, while STW used the second harmonic (1,913 KHz). The only other difference is in the timing signal used to operate each circuit. MSK and STW are highly compatible with each other in terms of detection circuits.

MSK stores information in a local area making use of strong phase change of the fundamental wave and therefore has an excellent SNR. STW is not prone to performance degradation caused by positional shifts as its information is distributed in a wide area spanning 37 cycles. In contrast, MSK provides better position information as a bit sync for finding the head of an ADIP Unit. STW laid out in a wide area is insensitive and robust against local defects. An outcome of the combination of MSK and STW in an address format is the achievement of substantial robustness against different types of distortions, such as noise and defects, and satisfactory high performance for accurate positioning and against Wobble shifts.

Fig. 5.3

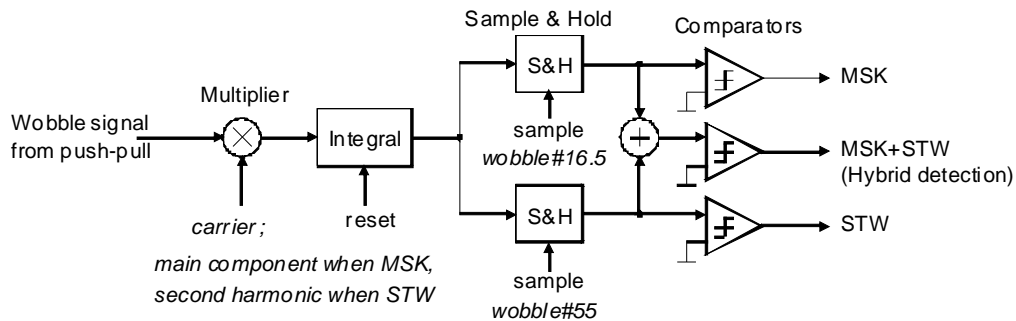

An example of the heterodyne detection circuit for the MSK marks and the STWs. Both of the MSK marks and STWs can be detected using the common circuit by only changing frequency of the carrier supplied to the multiplier.

Reference ADIP Unit

Wobble beats, which are beats at the fundamental frequency of Wobbles, occur substantially as the Groove on BD is a narrow-pitched Groove. These beats modulate both the amplitude and phase of the detected single-frequency component. Consequently, detection quality of both MSK and STW degrades due to the beats. Hence the physical length of one Wobble cycle was optimized to minimize the influence of beats and was established to be equivalent to 69 writing Channel clock signals. Furthermore, reference ADIP Units, which are inserted at every 5 ADIP Units, can correct the influence of beats. The reference ADIP Unit is comprised of STW of data 0. Since the Unit is known to be 0 in advance, it becomes possible to correct a phase shift so that the detected value is precisely data 0.

Reference:

“Wobble-address format of the Blu-ray Disc”, S. Furumiya et al., JJAP, Vol. 42, No. 2B (February 2003)

6. Disc Management

The use of recordable DVD optical discs has become increasingly widespread because of their large capacity of up to 4.7 GB, cost effectiveness and good interchangeability. A blue laser design with 0.1 mm Cover thickness and Multi Layer recording technology now expands this capacity to 100 GB over. Such high capacity media require an error free recording space and random recordability. A disc management system containing defect management and recording management has been developed for the BD-R Disc. Defect management enables an error free recording space and logical overwrite (LOW), while recording management enables and controls either sequential recording or random recording on BD-R (see section 6.2). This Logical OverWrite (LOW) feature simplifies file system designs by making Blu-ray™ Recordable discs behave similarly to Blu-ray™ Rewritable discs.

6.1. Defect Management and Logical Overwrite

To provide an error free volume space to the file system, defect management methods have been widely used for rewritable media. This part of the disc management system replaces defective Data Units with a correct version in a pre-assigned Spare Area. Such a replacement scheme has been carefully designed for BD-R taking into account the write-once characteristics of these media.

The BD-R disc has an Inner Spare Area (ISA) and Outer Spare Area (OSA) in each layer like BD-RE (Blu-ray Disc™ Rewritable) shown in Fig. 6.1.1. These areas are divided into Temporary Disc Management Areas (TDMAs) and available spare replacements. In general, one quarter of the Inner and Outer Spare Area is provided for TDMAs, leaving the remainder to replace defects. In addition, TDMAs are allocated in the Lead-in of Layer 0 and Lead-out of Layer 1. Temporary Disc Management Structures (TDMSs) are stored consecutively in the TDMAs. This construction allows many updates of the TDMS during use of the disc.(Fig. 6.1.2)

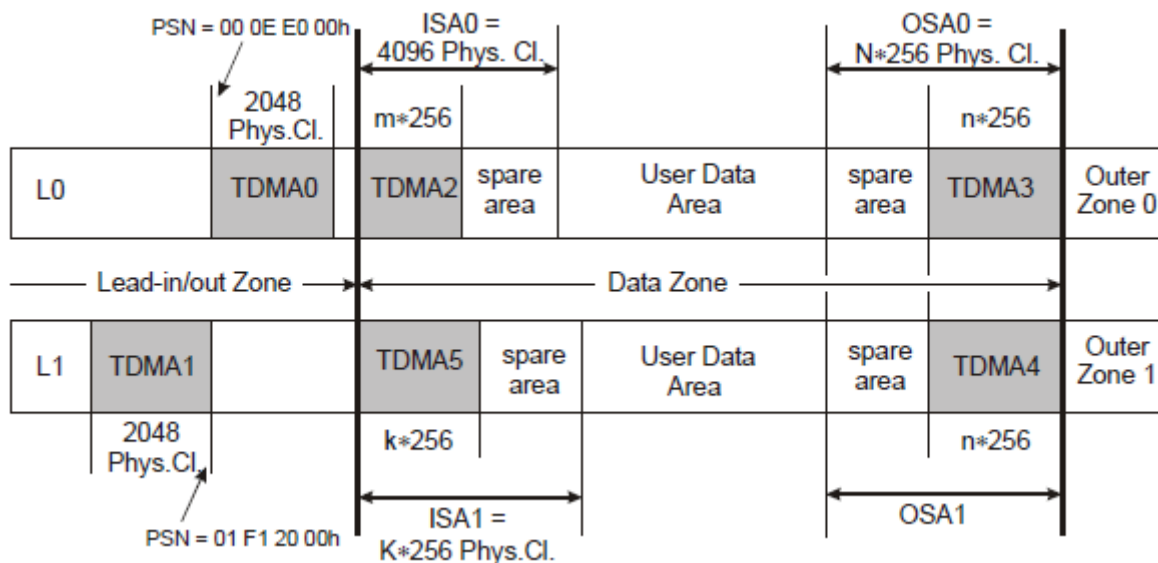

Fig. 6.1.1. Location of the TDMAs on the disc

A TDMS contains the basic disc management information. This consists of the Temporary Disc Definition Structure (TDDS), the Temporary Defect List (TDFL) and the recording management information. There are two mutually exclusive types of recording management information, SRRI and SBM. They will be explained in section 6.2.

For quick accessing of the latest contents of a TDMS, the TDDS, which has pointers to the other elements, is always recorded at the end of the TDMS at every update.

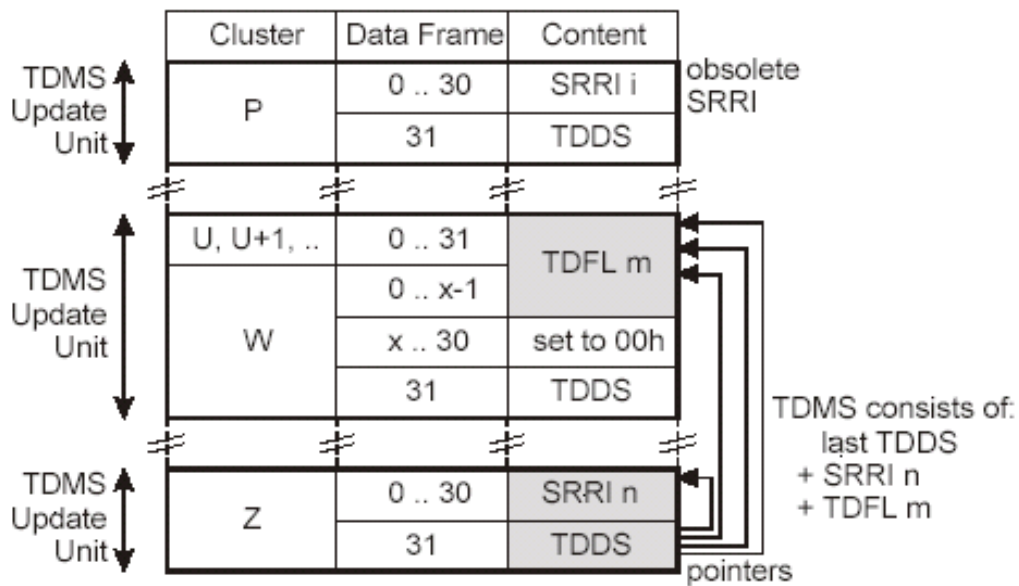

Fig. 6.1.2. TDMA contents.

The TDFL lists any defect locations and their corresponding replacement locations allocated by the defect management system. To reduce TDMA consumption, the TDFL is of variable size and does not have a list of usable spare locations. Rather, the TDDS contains the next available spare replacement location for each Spare Area.

At disc closure, the contents of the latest TDMS are copied into DMAs located at positions corresponding to those in the BD-RE standard. Once this is done, because write-once recording on BD-R is permanent, it is impossible to modify the disc management information in the DMAs which contain the replacement information and the User Recorded Area. This feature can guard against unwanted modifications.

Since this defect management design for BD-R uses linear replacement, it is possible to employ it for logical overwriting of already written user data, thus effectively mimicking a rewritable medium. Such logical overwriting (writing to the same LSN, but actually recording at a reassigned PSN by linear replacement) is treated in the similar way as defect management, i.e. the information about the redirections is stored in the same Defect List.(Fig. 6.1.3)

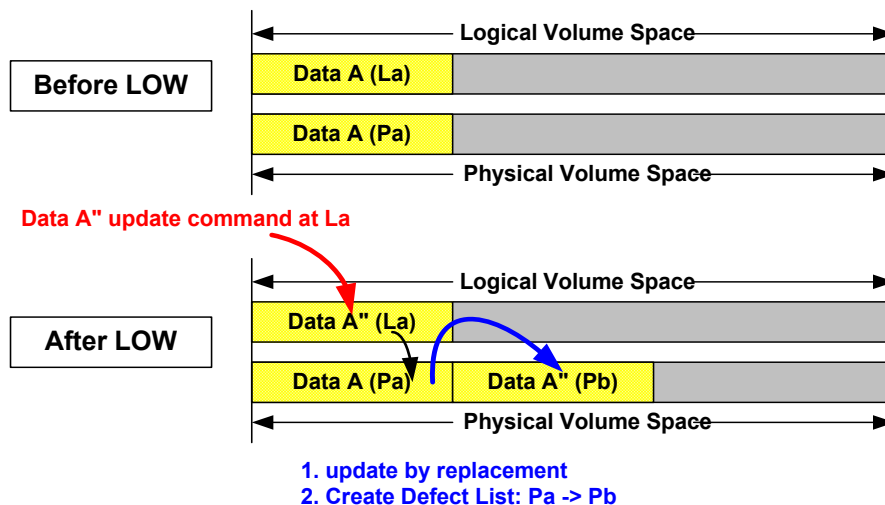

Fig. 6.1.3. LOW Replacement

6.2 Recording Management

Legacy compatibility is one of the major goals of BD-R. To provide a compatible recording method to legacy write-once media (e.g., CD-R, DVD-R, DVD+R) and to provide maximum recording compatibility among the BD disc family, the BD-R system provides two kinds of recording modes. They are Sequential Recording Mode and Random Recording Mode.

In the Sequential Recording Mode, existing sequential recording applications are easily modified for use with the BD-R disc. The BD-R drive makes use of a logical Track that is referred to as Sequential Recording Range (SRR) and logical sessions just like other sequential recording media, while still providing the flexibility of allowing simultaneous recording with up to sixteen open SRRs. This scheme is controlled with Sequential Recording Range Information (SRRi).

Unlike CD-R and other recordable optical media, for BD-R it is not required to fill up the unrecorded areas to make the disc readable by other BD drives such as BD-ROM. This feature will reduce the time for closure operation (i.e. Track/session/disc closing) in comparison to legacy sequential recording media. In addition, the linear replacement defect management scheme enables the logical overwrite of previously recorded user data on a BD-R disc.

One of the outstanding features of BD-R is the support of a Random Recording Mode. It is possible to record User Data randomly on a BD-R disc on a 64 KByte ECC Cluster basis. The BD-R drive applies a Space Bit Map (SBM) to manage recorded/unrecorded areas during the Random Recording Mode. This Random Recording Mode in BD-R offers the same recording experience as for BD-RE.

Besides the provision of an error free volume space and a broad choice of recording modes, this design also creates an important improvement in the robustness of the disc management information structure. For correct retrieval of the User Data, additional information is provided to enable reconstruction methods designed to obtain the required information even in the case of possible damage to some of the disc management structures. Among this new information are an inconsistency flag for conformity checking, writing the defective Cluster address in the replacement Cluster and a padding Cluster for detection of a closed SRR with an unwritten area.

The most recent TDMS information including TDDS, TDFL and recording management information can be recovered through these reconstruction methods. This feature improves the robustness of the disc structure and also reduces the disc space needed for a disc management information update.